

---

---

**AGENDA**  
**CUMBERLAND COUNTY BOARD OF COMMISSIONERS**  
**COURTHOUSE – ROOM 118**  
**MAY 21, 2007**  
**6:45 PM**

---

---

INVOCATION - Commissioner Jeannette Council

PLEDGE OF ALLEGIANCE –

**PUBLIC COMMENT PERIOD (6:45 PM – 7:00 PM)**

**Special Recognition:**

Cumberland County Cares Award - Rhonda Washington – Rhonda’s Rainbow Family of Dance

1. Consent Agenda

- A. Approval of minutes for the May 7, 2007 regular meeting.
- B. Approval of Ordinance Assessing Property for the Cost of Demolition:
  - 1) Case Number MH 4784-2006  
Property Owner: Katherine & Kenneth Fisher  
Property Location: Lot to Left of 3554 Hidden Oaks Drive, Fayetteville, NC  
Parcel ID Number: 0452-46-6548
  - 2) Case Number MH 4690-2005  
Property Owner: Mary Hills Troy  
Property Location: 2024 Memory Lane, Fayetteville, NC  
Parcel ID Number: 0443-11-2170
- C. Approval of Memorandum of Understanding Between Institute for Community Leadership Partners.
- D. Approval of Resolution of Intent to Exchange with Shooters Supply Certain Personal Property Declared Surplus by Sheriff.
- E. Approval of the Cumberland County Juvenile Crime Prevention Council Contracts Representing Funding Allocations for July 1, 2007 through June 30, 2008.

- F. Approval of Settlement Agreement in Kagan v. Mosley.
- G. Approval of Sale of Surplus County-Owned Real Property Acquired by Tax Foreclosure:
  - 1) Res 314 Maloney Ave - Lots 21-22  
(Located on Maloney Ave, off Grove Street)  
PIN 0437-95-9834; Cross Creek Township

H. Budget Revisions:

- (1) Injured Animal Stabilization Fund

Revision in the amount of \$4,000 to appropriate injured animal fund balance for additional veterinarian bills. (B07-345) **Funding Source – Injured Animal Stabilization Fund Balance**

- (2) Kelly Hills Water and Sewer

Revision in the amount of \$24,904 to transfer sales tax revenue and maintenance fees from the Kelly Hills capital project fund to the Kelly Hills maintenance fund in order to close out the capital fund and establish an ongoing maintenance fund. (B07-341 and B07-341A) **Funding Source – Other**

- (3) Register of Deeds

Revision in the amount of \$25,047 to budget additional revenue and expenditures anticipated for the remainder of the fiscal year. (B07-342) **Funding Source – Fees**

- (4) Cumberland Day Reporting Center

Revision in the amount of \$21,700 to recognize additional state funds to purchase a van. (B07-340) **Funding Source – State**

- (5) Welfare Other

Revision in the amount of \$2,000 to budget additional revenue for the NC Child Trust. (B07-349) **Funding Source – Fees**

(6) Mental Health

- a. Substance Abuse Contracts - Revision in the amount of \$45,069 to budget additional state funding for start up and operations of adolescent substance abuse services. (B07-343) **Funding Source – State**
- b. Developmental Disability Contracts – Revision in the amount of \$66,500 to increase budget for medical supplies funded by Medicaid. (B07-344) **Funding Source - Fees**

(7) Recreation and Parks

Revision in the amount of \$202,100 to budget additional revenue anticipated for the remainder of the fiscal year. (B07-347) **Funding Source – Recreation Tax**

(8) Recreation – Hope Mills

Revision in the amount of \$18,000 to budget additional revenue anticipated for the remainder of the fiscal year. (B07-348) **Funding Source – Hope Mills Recreation Tax**

(9) School Capital Outlay Fund

- a. Buildings- Revision in the amount of \$159,000 to reduce fund balance appropriated and expenditures based upon actual expenditures. (B07-346) **Funding Source – School Fund Balance Appropriated**
- b. Equipment- Revision in the amount of \$79,897 to appropriate fund balance to purchase equipment. (B07-346A) **Funding Source – School Fund Balance Appropriated**
- c. Vehicles- Revision in the amount of \$20,897 to reduce appropriate fund balance and expenditures based upon actual expenditures. (B07-346B) **Funding Source – School Fund Balance Appropriated**

(10) Sheriff

- a. Revision in the amount of \$6,552 to recognize Department of Justice Bulletproof Vest Grant. (B07-350) **Funding Source – Federal Grant**

- b. Revision in the total amount of \$28,750 to recognize a \$23,000 pass-through State Gang Violence Grant and an in-kind match of \$5,750. (B07-351)

**Funding Source – Fees**

- (11) Animal Control

Revision in the amount of \$38,091 to appropriate fund balance to cover expenditures for the remainder of FY2007. (B07-351) **Funding Source – General Fund Fund Balance**

2. Public Hearings

**Uncontested Cases**

**Rezoning**

- A. Case P07-24. The rezoning of .34 acres from R10 to C1(P), or to a more restrictive zoning district, at 3639 Boone Trail, owned by Judy L. (Suggs) Morris.
- B. Case P07-26. The rezoning of a .24 acre portion of a 26.18 acre tract, from A1 to R15, or to a more restrictive zoning district, located south of Sand Hill Road, west of Tower Road, owned by Terry Spell Land Development, LLC.
- C. Case P07-27. The rezoning of three parcels totaling 47.24 acres from R6A to A1, located on the south side of Tom Starling Road, at Innisfree Place, owned by Patricia Leahy.
- D. Case P07-28. Initial zoning of .92 acres to RR (as a result of de-annexation by the Town of Hope Mills), located on the west side of Mission Hill Road, south of Oak Haven Road, owned by Dawn and William Stock.
- E. Case P07-30. The rezoning of .28 acres from R10 to O&I(P), or to a more restrictive zoning district, at 1449 E. Manchester Road, owned by Malcolm James.

**Contested Cases**

- F. Case P07-20. The rezoning of three parcels totaling 43.36 acres from A1 to R30, or to a more restrictive zoning district, located south of Dunn Road, east of Ringwood Drive, owned by Cain Builders, Inc.

### Conditional Use District & Permit Case

- G. Case P07-04. The rezoning of 44.32 +/- Ac from A1 to R15/Density Development/Conditional Use District & Permit, or to a more restrictive zoning district, located on the west side of Old Vander Road, northwest of Simmons Carter Road, owned by Gertrude V. Harris.

#### Items of Business

- 3. Nominations to Boards and Committees
  - A. ABC Board (2 Vacancies)
  - B. Animal Control Board (3 Vacancies)
  - C. Board of Adjustment (2 Vacancies)
  - D. Board of Health (1 Vacancy)
  - E. Criminal Justice Partnership Advisory Board (8 Vacancies)
  - F. Cumberland County Juvenile Crime Prevention Council (1 Vacancy)
  - G. Fayetteville Technical Community College Board of Trustees (1 Vacancy)
  - H. Human Relations Commission (2 Vacancies)
  - I. Jury Commission (1 Vacancy)
  - J. Nursing Home Advisory Board (1 Vacancy)
  - K. Parks & Recreation Advisory Commission (3 Vacancies)
  - L. Consideration of Joint Planning Board Request for Extension of Term of Clifton McNeil, Jr.
  - M. Storm Water Advisory Board (2 Vacancies)
  
- 4. Appointments to Boards and Committees
  - A. Adult Care Home Community Advisory Committee (1 Vacancy)  
Nominee: Benita Briggs

B. Community Child Protection Fatality Prevention Team (3 Vacancies)

Nominees:

EMS Provider or Firefighter Position: Barry Childers (New Appointment to fill unexpired term)

Parent of a Child Who Died Before Reaching their 18<sup>th</sup> Birthday Position: Tonya Vetter (New Appointment)

At-Large Position: Maxine Anders (New Appointment To fill unexpired term)

C. Juvenile Crime Prevention Council (1 Vacancy)

Nominee:

Member of Faith Community: Rev. Brian Thompson (Reappointment)

**RECESS THE BOARD OF COMMISSIONERS' REGULAR MEETING.**

**CONVENE THE KELLY HILLS/SLOCOMB ROAD WATER & SEWER DISTRICT GOVERNING BOARD MEETING (SEE SEPARATE AGENDA) / ADJOURN**

**RECONVENE THE REGULAR BOARD OF COMMISSIONERS' MEETING.**

5. Closed Session: A. Personnel Matter Pursuant to NCGS 143.318.11(a)(6).

**ADJOURN**

**THIS MEETING WILL BE BROADCAST LIVE ON TIME WARNER COMMUNITY CHANNEL 7.**

**MEETINGS: June 4, 2007 (Monday) - 9:00 AM  
June 18, 2007 (Monday) - 6:45 PM**

**\*\*\* NOTE: THERE ARE NO BOARD MEETINGS IN JULY \*\*\***

ORDINANCE ASSESSING PROPERTY FOR THE COSTS  
OF DEMOLITION OF A STRUCTURE PURSUANT TO  
THE MINIMUM HOUSING CODE OF CUMBERLAND COUNTY

WHEREAS, the Board of County Commissioners of Cumberland County, North Carolina, on November 20, 2006, enacted an ordinance directing the demolition by the owner(s) of the structure(s), Kathryn & Kenneth Fisher located at lot to left of 3554 Hidden Oaks Drive (PIN: 0452-46-6548), said ordinance being recorded at Book 7442, page 499, of the Cumberland County Registry of Deeds;

WHEREAS, the time within which said demolition was to be performed has expired and the owner(s) failed to comply with the ordinance within such period; and

WHEREAS, the said ordinance further directed the Minimum Housing Inspector to effect the demolition of the structure(s) in the event the owner(s) failed to do so;

WHEREAS, the Minimum Housing Inspector has reported to this Board that:

- (1) Said work had been accomplished.
- (2) The cost of such work was \$1,975.00.
- (3) There were no salable materials resulting from said work.

NOW THEREFORE, the above report coming on to be considered and the Board of County Commissioners finding it to be a true and accurate accounting, the said Board hereby ORDAINS:

(1) That the real property on which the work was performed be, and it hereby is, assessed in the amount of \$1,975.00, said sum being the unpaid balance of the cost of the work set forth in the Inspector's Report;

(2) That as provided in the Ordinance of Cumberland County dated November 20, 2006, and in Section 160A-443(6) of the General Statutes of North Carolina, the amount of the foregoing assessment be, and hereby does constitute, a lien against the real property upon which such costs were incurred, such property being more particularly described as follows:

The structure and premises located at lot to left of 3554 Hidden Oaks Drive, Fayetteville, NC, Gray's Creek Township, as described in Deed Book 3257, page 552, of the Cumberland County Registry and identified in County tax records as PIN 0452-46-6548.

(3) That as further provided in Section 160A-443(6) of the General Statutes of North Carolina, such lien shall be filed, have the same priority, and be collected as the lien for special assessment provided in Article 10 of Chapter 160A of said General Statutes;

(4) That one copy of this resolution be filed in the minutes of this Board of County Commissioners and another copy certified and delivered by the Clerk as a charge to the Tax Collector, who shall thereupon enter the amount of the assessment set forth above upon the Tax Books of the County as a special assessment against the above described property.

\* \* \* \* \*

I certify that the foregoing Ordinance was adopted and ordered by the Board of Commissioners of Cumberland County, North Carolina, this 21<sup>st</sup> day of May, 2007, at 6:45'clock P.M.

\_\_\_\_\_  
Cumberland County Clerk



ORDINANCE ASSESSING PROPERTY FOR THE COSTS  
OF DEMOLITION OF A STRUCTURE PURSUANT TO  
THE MINIMUM HOUSING CODE OF CUMBERLAND COUNTY

WHEREAS, the Board of County Commissioners of Cumberland County, North Carolina, on December 18, 2006, enacted an ordinance directing the demolition by the owner(s) of the structure(s), Mary Hills Troy located at 2024 Memory Lane (PIN:0443-11-2170), said ordinance being recorded at Book 7455, page 475, of the Cumberland County Registry of Deeds;

WHEREAS, the time within which said demolition was to be performed has expired and the owner(s) failed to comply with the ordinance within such period; and

WHEREAS, the said ordinance further directed the Minimum Housing Inspector to effect the demolition of the structure(s) in the event the owner(s) failed to do so;

WHEREAS, the Minimum Housing Inspector has reported to this Board that:

- (1) Said work had been accomplished.
- (2) The cost of such work was \$1,900.00.
- (3) There were no salable materials resulting from said work.

NOW THEREFORE, the above report coming on to be considered and the Board of County Commissioners finding it to be a true and accurate accounting, the said Board hereby ORDAINS:

(1) That the real property on which the work was performed be, and it hereby is, assessed in the amount of \$1,900.00, said sum being the unpaid balance of the cost of the work set forth in the Inspector's Report;

(2) That as provided in the Ordinance of Cumberland County dated December 18, 2006, and in Section 160A-443(6) of the General Statutes of North Carolina, the amount of the foregoing assessment be, and hereby does constitute, a lien against the real property upon which such costs were incurred, such property being more particularly described as follows:

The structure and premises located at 2024 Memory Lane, Fayetteville, NC, as described in Deed Book 5145, page 65, of the Cumberland County Registry and identified in County tax records as PIN 0443-11-2170.

(3) That as further provided in Section 160A-443(6) of the General Statutes of North Carolina, such lien shall be filed, have the same priority, and be collected as the lien for special assessment provided in Article 10 of Chapter 160A of said General Statutes;

(4) That one copy of this resolution be filed in the minutes of this Board of County Commissioners and another copy certified and delivered by the Clerk as a charge to the Tax Collector, who shall thereupon enter the amount of the assessment set forth above upon the Tax Books of the County as a special assessment against the above described property.

\* \* \* \* \*

I certify that the foregoing Ordinance was adopted and ordered by the Board of Commissioners of Cumberland County, North Carolina, this 21<sup>st</sup> day of May, 2007, at 6:45'clock P.M.

\_\_\_\_\_  
Cumberland County Clerk



ITEM NO. 1C

## COUNTY of CUMBERLAND

James E. Martin  
County Manager

Cliff Spiller  
Assistant County Manager

Juanita Pilgrim  
Deputy County Manager

Office of the County Manager

Amy H. Cannon  
Assistant County Manager

### MEMORANDUM FOR BOARD OF COMMISSIONERS AGENDA OF MAY 21, 2007

**TO:** BOARD OF COUNTY COMMISSIONERS

**FROM:** JUANITA PILGRIM, DEPUTY COUNTY MANAGER 

**DATE:** MAY 14, 2007

**SUBJECT:** CONSIDERATION OF APPROVAL OF MEMORANDUM OF UNDERSTANDING BETWEEN INSTITUTE FOR COMMUNITY LEADERSHIP PARTNERS

#### BACKGROUND:

Now in its fourth year, the Institute for Community Leadership is a joint venture of Cumberland County, the City of Fayetteville, Fayetteville State University, Fayetteville Technical Community College, Methodist University, and the Cumberland County School System. The Institute has as its purpose to identify, develop, and empower members of our community who are willing to commit to leadership roles in addressing issues affecting Cumberland County. The goal is to provide community leadership boards, both non-profit and governmental, with applicants who are trained in leadership and knowledgeable of board functions and opportunities for service.

Potential participants are members of our community who are committed to the interests of the community; respected by others and who often influences the opinions of others; that may not have access to this type of training; and who are generally knowledgeable about important issues affecting the community.

Since 2004, ICL has graduated 89 residents of Cumberland County. ICL alumni are currently serving on the Hope Mills Youth Association Board, Fayetteville Observer Credit Union Board, Fayetteville Area Habitat for Humanity Board of Advisors, Administrative Council of Harry Hosier United Methodist Church, Mental Health Board, Human Relations Commission, and the Child Advocacy Center of Cumberland County Board.

#### RECOMMENDATION/PROPOSED ACTION:

Partners agreed to host the program at their respective organizations for a period of two years every ten years. Cumberland County will host the program June 1, 2015- May 31, 2017. Management recommends approval of the attached Memorandum of Understanding.

**MEMORANDUM OF UNDERSTANDING (MOU) BETWEEN  
INSTITUTE FOR COMMUNITY LEADERSHIP PARTNERS**

This Memorandum of Understanding (MOU) is entered into between **Cumberland County**, 117 Dick Street, Fayetteville, NC 28301, the **City of Fayetteville**, 433 Hay Street Fayetteville, NC 28301, **Fayetteville State University (FSU)**, 1200 Murchison Road, Newbold Station, **Fayetteville Technical Community College**, P.O. Box 35236 Fayetteville, NC 28303, **Methodist University**, 5400 Ramsey Street Fayetteville, NC 28311, and the **Cumberland County School System**, 2465 Gillespie Street Fayetteville NC 28306, all referred to below as ICL Partners.

The purpose of this MOU is to solidify the pre-existing partnership and outline the duties and the responsibilities of each partner.

WHEREAS the ICL Partners have a mutual interest in providing community leadership boards, both non-profit and governmental, with applicants who are trained in leadership and cognizant of board functions and opportunities for service and who have not previously taken leadership roles;

NOW THEREFORE the Parties agree as follows:

**Article I. SCOPE**

It is the understanding of the Parties that the goal of this program is to identify and enroll a minimum of twenty-five and maximum of forty interested citizens, provide at least five, but no more than seven sessions that provide leadership training, introduction to boards and commissions, overview of board/commission members responsibilities, opportunities for networking and presentation of volunteer opportunities. These individuals will have demonstrated leadership ability and interest in the community but have not taken a significant leadership role in any local activity.

**Article II. LOCATION**

Partners agree to host the program at their respective organizations for a period of two years every ten years. Fayetteville State University will serve as host for the Institute for Community Leadership (ICL) from June 1, 2005-May 31, 2007. The host schedule for the ten-year period beginning June 1, 2007 will be:

June 1, 2007-May 31, 2009	Methodist University
June 1, 2009-May 31, 2011	Fayetteville Technical Community College
June 1, 2011-May 31, 2013	Cumberland County School System
June 1, 2013-May 31, 2015	City of Fayetteville
June 1, 2015-May 31, 2017	Cumberland County
June 1, 2017-May 31, 2019	Fayetteville State University

### Article III. ROLES AND RESPONSIBILITIES

#### 1. Financial Commitment

- a. Program funding is a critical issue. This program will continue to be free to participants and each partner shall contribute a minimum of six hundred dollars (\$600) per year to partners. The program's operating budget will be reviewed in April of each year to determine whether there shall be an increase in partner contributions.
- b. These contributions will be used primarily to pay tuition for students and training session expense for facilitators and program administrators.
- c. The Executive Director shall present a budget to the ICL Board for approval at the May meeting.

#### 2. Program Commitment

- a. Each partner shall serve as an ambassador for the Institute for Community Leadership.
- b. **Board Meeting:** Partners agree to host a meeting of the ICL Board approximately twice a year according to an agreed upon rotation. Meetings are typically held the First Tues of a month, from 9:00 a.m. until 11:00 a.m., every other month. Responsibilities include:
  - i. chair the meetings
  - ii. publish agenda
  - iii. provide copies of the agenda, minutes of the previous meeting, and other handout
  - iv. provide someone to take minutes, and then distribute the minutes by email to board members
  - v. ensure parking is reserved for attendees.
  - vi. provide light refreshments.
- c. Each partner shall appoint at least one (1) representative to serve on the ICL Board. Each partner shall identify one (1) alternate with decision-making authority who may attend ICL Board meetings in their absence.
- d. Each partner shall attend (or send a representative) to each ICL Board Meeting.
- e. Each partner shall nominate participants and submit those nominations in writing to the Executive Director by June 30, 2006.
- f. **Sessions:** Each partner shall sponsor one program session per the schedule drafted by the Executive Director and approved by the ICL Board. Partner responsibilities associated with the program sessions are:
  - i. Provide an administrative contact to handle session logistics, including but not limited to securing a location, providing refreshments, identifying and confirming presenters, panelists and trainers, participant attendance and distribution and collection of evaluations. This contact will be responsible for providing to the Executive Director the attendance sheet and evaluation no later than seven (7) days following the session.
  - ii. Provide the Executive Director materials listed in "Participant Notebook Contents" by August 31.

- iii. Provide an agenda and copies of handouts/materials related to the agenda at least three weeks (21 working days) before the scheduled session.

3. **Administration**

- a. The host organization shall administer the Institute for Community Leadership by providing the following:
  - i. Staff support to serve as Executive Director
  - ii. Office space
  - iii. Marketing
  - iv. Graduation certificates
  - v. Leadership self-assessments
  - vi. Miscellaneous supplies
- b. Methodist University shall handle budget reconciliation and collection of partner contributions.

**Article IV. Effective date of agreement**

This MOU is effective upon signature of the parties and will remain in effect unless and until terminated as provided under Article VI.

**Article V. Purpose or intent of parties entering the MOU**

The purpose of the memorandum is to provide a general understanding and agreement that all parties are intent upon providing a well-run and supported program to address the need for leadership in our community.

**Article VI. Term of agreement**

This MOU is effective upon signature of the parties and will remain in effect for a period of twelve (12) months from the effective date or unless terminated as provided under Article IX or unless superseded by the execution of a contract by the parties that is related to this MOU.

**Article VII. Severability clause (if applicable)**

Nothing in this MOU is intended to conflict with the current laws, regulations, or directives of the state of North Carolina or the University of North Carolina System. If an article of this MOU is inconsistent with such authority, then that term shall be invalid, but the remaining terms and conditions of this MOU shall remain in full force and effect.

**Article VIII. Notices**

The principal contacts between the parties for communicating notices shall be addressed as follows:

<i>Administrative</i>	<i>Contact</i>
Name	Ms. Emily M. Dickens
Address	1200 Murchison Road Fayetteville, NC 28301
Phone:	910-672-2101

FAX:	910-672-2198
E-Mail:	edickens@uncfsu.edu

<i>Partner</i>	<b>Cumberland County</b>
Name	Ms. Juanita Pilgrim
Address	117 Dick Street, Fayetteville, NC 28301
Phone:	910-678-7726
FAX:	
E-Mail:	

<i>Partner</i>	<b>City of Fayetteville Contact</b>
Name	Mr. Dale Iman
Address	433 Hay Street, Fayetteville, NC 28301
Phone:	
FAX:	
E-Mail:	

<i>Partner</i>	<b>Fayetteville State University (FSU) Contact</b>
Name	Dr. T.J. Bryan
Address	Address: 1200 Murchison Road Newbold Station Fayetteville, NC 28301-4298
Phone:	(910) 672-1174
FAX:	(910) 672-1200
E-Mail:	

<i>Partner</i>	<b>Fayetteville Technical Community College (FTCC) Contact</b>
Name	Dr. Larry Norris
Address	P.O. Box 35236 Fayetteville, NC 28303
Phone:	910-678-9889
FAX:	
E-Mail:	

<i>Partner</i>	<b>Methodist University Contact</b>
Name:	Dr. Elton Hendricks
Address:	5400 Ramsey Street Fayetteville, NC 28311
Phone:	910-630-7005
FAX:	
E-Mail:	

<i>Partner</i>	<b>Cumberland County School System Contact</b>
Name	Dr. Bill Harrison
Address	117 Dick Street, Fayetteville, NC 28301
Phone:	910-678-2300
FAX:	
E-Mail:	

**Article IX. Termination of agreement**

This MOU shall terminate after **one year** from the effective date of last signature below, unless extended by mutual agreement, or may be terminated earlier by any Party by thirty (30) days written notice to the other parties. It is understood that this MOU shall be superseded by any subsequent agreement that may be entered into by the Parties as a result of this MOU. This MOU may be signed in one or more counterparts (including faxed copies), each of which shall be deemed one and the same original.

**Article X. Rights and Privileges**

This MOU is not intended to create or confer any rights, privileges, or benefits for any private person or party.

AGREED TO BY:

**Cumberland County**

**City of Fayetteville**

By: \_\_\_\_\_

By: \_\_\_\_\_

Name: Ms. Juanita Pilgrim  
Title: Deputy County Manager

Name: Mr. Dale Iman  
Title: City Manager

Date: \_\_\_\_\_

Date: \_\_\_\_\_

**Fayetteville State University**

**Fayetteville Technical Community  
College**

By: \_\_\_\_\_

By: \_\_\_\_\_

Name: Dr. T. J. Bryan  
Title: Chancellor

Name: Dr. Larry Norris  
Title: President

Date: \_\_\_\_\_

Date: \_\_\_\_\_

**Methodist University**

**Cumberland County School System**

By: \_\_\_\_\_

By: \_\_\_\_\_

Name: Dr. Elton Hendricks  
Title: President

Name: Dr. Bill Harrison  
Title: Superintendent

Date: \_\_\_\_\_

Date: \_\_\_\_\_



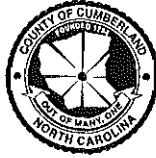

ITEM NO. 1D

## COUNTY of CUMBERLAND

Office of the County Attorney

May 7, 2007

**MEMORANDUM FOR BOARD OF COMMISSIONERS' AGENDA OF MAY 21, 2007**

**TO: BOARD OF COMMISSIONERS**

**FROM: GRAINGER R. BARRETT, COUNTY ATTORNEY** *GRB*

**SUBJECT: APPROVAL OF RESOLUTION OF INTENT TO EXCHANGE WITH SHOOTERS SUPPLY CERTAIN PERSONAL PROPERTY DECLARED SURPLUS BY SHERIFF**

**BACKGROUND:** Sheriff Butler requests that the Board of Commissioners authorize his Office to approve an exchange of certain personal property declared surplus by his Office with Shooters Supply, Fayetteville, N.C. for certain specialized equipment, as noted in the attached. The estimated value of the property changing hands is \$10,114.00. Please refer to the enclosed memorandum from Sheriff Butler dated March 29, 2007. G.S. 160A-271 authorizes the Board to approve an exchange of property provided it publishes notice.

**RECOMMENDATION:** Approve resolution of intent to exchange personal property with Shooters Supply, as listed in the enclosed memorandum from Sheriff Butler. The Board may take final action approving the exchange at its next meeting, on June 4, 2007.

Encl.

**CUMBERLAND COUNTY BOARD OF COMMISSIONERS  
RESOLUTION OF INTENT TO EXCHANGE CERTAIN PERSONAL  
PROPERTY WITH  
SHOOTERS SUPPLY, PURSUANT TO G.S. 160A-271**

BE IT RESOLVED that at its next regular meeting to be held at the Cumberland County Courthouse on June 4, 2007, at 9:00 a.m., the Cumberland County Board of Commissioners intends to adopt a resolution authorizing the exchange of certain personal property declared surplus by the Cumberland County Sheriff's Office for specialized equipment to be exchanged with Shooters Supply, Fayetteville, N.C., as more particularly described in the memorandum from Sheriff Earl R. Butler included in the agenda of this meeting.

BE IT FURTHER RESOLVED that the Clerk to the Board shall advertise notice of this intent in conformance with G.S. 160A-271.

Adopted at a regular meeting held May 21, 2007.

---

Kenneth S. Edge, Chairman  
Cumberland County Board of Commissioners

---

Marsha Fogle  
Clerk to the Board

NOTICE BY CUMBERLAND COUNTY BOARD OF COMMISSIONERS OF INTENT TO  
EXCHANGE CERTAIN PERSONAL PROPERTY WITH  
SHOOTERS SUPPLY, PURSUANT TO G.S. 160A-271

Cumberland County gives notice that the Board of Commissioners intends to consider a resolution at its next regular meeting on June 4, 2007, authorizing the Cumberland County Sheriff's Office to exchange with Shooters Supply, Fayetteville, N.C. certain surplus Sheriff's Office shotguns and pistols/revolvers in exchange for twelve (12) upper receiver assemblies, as more fully set forth in the attached itemization. The Sheriff's Office has determined that the value of the consideration to be exchanged is \$10,114.00. Details concerning the proposed exchange are available from the Cumberland County Sheriff's Office, 678-5410.

Published:



EARL R. BUTLER, SHERIFF  
CUMBERLAND COUNTY SHERIFF'S OFFICE

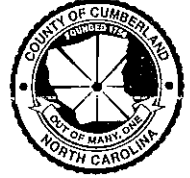

An Internationally Accredited Law Enforcement Agency

MAR 30 2007

March 29, 2007

To: James Martin, County Manager

Fr: Earl R. Butler, Sheriff *ERB*

Re: Weapons Trade Request

---

It is our desire to trade weapons that are currently in our inventory that are not being utilized, in order to upgrade and modernize the weapons being used by our Special Response Team.

We have proposed a tentative trade agreement with Shooters Supply, 5103 Bragg Boulevard, Fayetteville, NC to do an even trade on specialized equipment/weapons with no money exchanged.

These trade-ins are beneficial to the Sheriff's Office, allowing us to upgrade weapons as well as dispose of weapons which are either outdated, or in need of repair and are not being used.

Thanks in advance for your assistance in fulfilling this request. If you have any questions, please do not hesitate to contact this office.

/attachments

cc: Grainger Barrett, County Attorney ✓

## Weapons Trade List

### HANDGUNS

Browning Hi-Power	9mm	Ser# 72C47056
Beretta 84BB	9mm	Ser# D20101Y
Colt semi-auto	.32	Ser# 409416
Colt Anaconda Revolver 8"	.357	Ser# MM26313
Colt Govt model 70	.45	Ser# 90586G70
Colt Govt model 70	9mm	Ser# 70L24200
Colt Govt model 70	.45	Ser# 70B36704
Colt Lawman Revolver 2 1/2"	.38	Ser# 43596L
Glock 17	9mm	Ser# ABY928US
Glock 19	9mm	Ser# GS552US
Glock 22	9mm	Ser# RU235US
Rossi Revolver 4"	.38	Ser# D603625
Rossi Revolver 2 1/2"	.38	Ser# AA144814
Ruger Security Six Revolver	.357	Ser# 160-57446
Ruger Blackhawk Revolver 8"	.44	Ser# 83-92932
Ruger P95DC	9mm	Ser# 312-43212
Ruger P-85	9mm	Ser# 30390271
Ruger P-89		Ser# 30440713
S&W model 65 Revolver 4"	.357	Ser# 1D44470
S&W model 10 Revolver 4"	.38	Ser# D333507
S&W model 29 Revolver 6"	.44	Ser# BRU7783
S&W model 66 Revolver 4"	.357	Ser# AUK8948
S&W model 686 Revolver 4	.357	Ser# AUL1581M
S&W SW40VE	.40	Ser#
S&W SW40V	.40	Ser# PAU1493
Springfield Champion	.45	Ser# N345189
Springfield 1911	.45	Ser# NM47661
Springfield XD-9	9mm	Ser# US952128
Taurus Revolver 2 1/2"	.38	Ser# ML25946

### SHOTGUNS

Coast to Coast	12 Ga.	Ser# B109217
High Standard K-1200	12 Ga.	Ser# SD-9 (parts)
High Standard K-1200	12 Ga.	Ser# SD-10 (parts)
High Standard K-1200	12 Ga.	Ser# 3038620 (parts)
High Standard K-1200	12 Ga.	Ser# Unk-#1
High Standard K-1200	12 Ga.	Ser# Unk-#3
High Standard K-1200	12 Ga.	Ser# SD-6
High Standard K-1200	12 Ga.	Ser# 3039243
High Standard K-1200	12 Ga.	Ser# 3039240

Mossberg 500-A	12 Ga.	Ser# L614273
Mossberg 835	12 Ga.	Ser# UM499580
Mossberg 500-A (pistol grip)	12 Ga.	Ser# R178868
Mossberg 500-A (pistol grip)	12 Ga.	Ser# L696321
Mossberg 500-A (fire damage)	12 Ga.	Ser# P384148
Mossberg 500-A (damaged)	12 Ga.	Ser# P384245
Maverick 88 (pistol grip)	12 Ga.	Ser# M71821J
New England SB-1	20 Ga.	Ser# NF325068
Remington 11-87	12 Ga.	Ser# PC438200
Winchester 1200	12 Ga.	Ser# L679788



5103 Bragg Blvd.  
Fayetteville, NC 28303  
910.860.3700 phone  
910.860.4719 fax  
[www.shooters-supply.net](http://www.shooters-supply.net)  
[davidm@shooters-supply.net](mailto:davidm@shooters-supply.net)

March 15, 2007

Cumberland County Sheriffs Dept:

This is confirmation that Shooters Supply agrees to trade a quantity of 12 upper receiver assemblies for the total of guns on the attached list. Delivery of upper receivers will be at time of delivery of guns to our store. Below are the specs of the upper receivers being traded:

11.5" flat-top upper chrome moly bbl..no bolt..no charging handle..comes with tac latch  
YHM 2-pc rail handguard  
4 position stock  
YHM rear flip sight  
EO Tech 512 AA Battery  
Surefire light: G2 light/vertical grip/VTAC mount  
Troy single point sling w HK claw  
Phantom flash suppressor  
Ambi sling plate

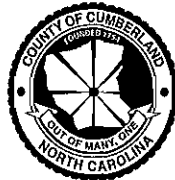

# COUNTY of CUMBERLAND



*Office of the County Manager*

James E. Martin  
County Manager

Cliff Spiller  
Assistant County Manager

Juanita Pilgrim  
Deputy County Manager

Amy H. Cannon  
Assistant County Manager

## MEMORANDUM FOR BOARD OF COMMISSIONERS AGENDA OF MAY 21, 2007

**TO:** BOARD OF COUNTY COMMISSIONERS

**FROM:** JAMES E. MARTIN, COUNTY MANAGER 

**DATE:** MAY 11, 2007

**SUBJECT:** APPROVAL OF THE CUMBERLAND COUNTY JUVENILE CRIME PREVENTION COUNCIL CONTRACTS REPRESENTING FUNDING ALLOCATIONS FOR JULY 1, 2007 THROUGH JUNE 30, 2008

### BACKGROUND

The Cumberland County Juvenile Crime Prevention Council annually submits the JCPC Program Contracts to the Board of Commissioners for approval prior to submitting to the State office. The contracts represent the funding allocations for FY08.

### RECOMMENDATION/PROPOSED ACTION

The Juvenile Crime Prevention Council recommends approval of the FY08 DJJDP County Funding Plan. A listing of the contracts is attached.

/ct

CM051107-1





# Cumberland County Juvenile Crime Prevention Council

Bringing Resources Together to Decrease Juvenile Crime and Strengthen Families and Communities

May 11, 2007

Gene Hallock, Chair  
Pat Hurley, Vice Chair  
Carol Hudson  
John Clark  
Debbie Jenkins  
Dr. Polly Davis  
Lt. Sherry Sparks  
Ron Snyder  
Margarita Dostall  
Krista Hancock  
Sue Thomas  
Joan Blanchard  
Beth A. Hall  
Billy R. King  
Archie Malloy  
Lynett Shakeel  
Lee Roberts  
Melvin Lindsay  
Juanita Pilgrim  
Honorable Edward A. Pone  
Cheri Siler-Mack  
Lt. Lynette Hodges  
Rev. Brian Thompson  
Tasha Jones, DJJDP Consultant

To: Mr. James Martin, County Manager  
Ms. Juanita Pilgrim, Deputy County Manager

Annually, the Department of Juvenile Justice & Delinquency Prevention provides funding to local county governments for the purpose of funding early intervention programs/services for youth that are involved in, or may become involved in, the juvenile court system.

After consideration of the 2007-2008 Department of Juvenile Justice & Delinquency Prevention's (DJJDP) projected allocations for local JCPC's, during our May meeting, held on Wednesday, May 9, 2007 regarding funding for the next fiscal year, the Juvenile Crime Prevention Council (JCPC) has completed their annual planning process. As part of that meeting, the JCPC voted unanimously to submit the council's funding recommendations and the 2007-2008 annual Comprehensive Planning document for Cumberland County and the DJJDP state program agreements for seven local programs.

Cumberland County is projected to receive \$940,867 in state dollars for fiscal year 2007-2008. Local matching funds are required in order to be eligible to receive these state funds. During the past, the County of Cumberland has generously contributed a portion of the required match. During the 2006-2007 fiscal year, the County of Cumberland provided the JCPC \$211,684 to support the programs funded by the JCPC. The local council gratefully acknowledges the ongoing support provided by the county.

This packet represents the funding recommendations the CCJCPC is making to the C.C. Board of Commissioners for their consideration during the May 21, 2007 meeting. The projected 2007-2008 funding plan is attached for review. Please feel free to contact me should you have any questions or require further assistance.

Regards,

Sarah Hemingway,  
Coordinator

A handwritten signature in cursive script, appearing to read "Gene Hallock".

# JCPC DJJDP/County Funding Requests for FY 2007-2008

Final Recommendation 5.09.07

Program Name	2006-2007 DJJDP Funding	FY 2007 County Matching funds	FY 07-08 DJJDP funds requested	Change in DJJDP request	County Cash requested for match FY 07- 08	Local Program Cash as a portion of match	Program Inkind as a portion of match	Other Program Cash	Total Program Budget Per Request	FY 07-08 Executive Committee Recommendation to Council members (DJJDP \$\$\$)	Fy 07-08 Executive Committee Recommendation for County Cash match
JAC	177,307	17,454	184,454	7,147	17,454		26,082	165,434	393,424	184,454	17,454
Find A Friend	51,911	9,657	51,911	0	9,657	13,996	29,280		104,844	51,911	9,657
Juvenile Court Outreach	134,738	25,414	156,730	21,992	25,414		36,762		218,906	156,730	25,414
C.C. Group Care	309,782	83,632	309,782	0	83,632			274,762	668,176	309,782	83,632
Fay/CC Restitution	95,635	13,386	97,635	2,000	12,152	12,151			121,938	84,251	12,152
HOPE Program	69,375	0	73,984	4,609	0		20,059		94,043	73,984	
Teen Court	56,449	14,641	56,449	0	14,641		17,136		88,226	56,449	14,641
Coordinator Budget		47,500		0	48,734				48,734		48,734
Administrative Budget	15,500		15,500	0					15,500	15,500	
JCPC Training/Other	30,170		7,806	(22,364)					7,806	7,806	
Totals	940,867	211,684	954,251	13,384	211,684	26,147	129,319	440,196	1,761,597	940,867	211,684

\* County match for FY

06-07 \$211,684

FY 07-08 projected

DJJDP allocation: \$940,867

Training funds for next fiscal year

FSU Youth & Families conference \$1500 requested for consideration

ITEM NO. IF

# COUNTY of CUMBERLAND

Office of the County Attorney

May 9, 2007

**MEMORANDUM FOR BOARD OF COMMISSIONERS MAY 21, 2007 AGENDA**

**TO: BOARD OF COMMISSIONERS**

**FROM: GRAINGER R. BARRETT, COUNTY ATTORNEY** *GRB*

**SUBJECT: APPROVAL OF SETTLEMENT AGREEMENT IN *KAGAN V. MOSLEY***

**BACKGROUND:** The Board of Commissioners has authorized settlement of this action. This lawsuit was filed by Plaintiff Kagan against, among others, the Sheriff's Office and Deputy L. Christian, alleging failure of a state law duty to provide adequate medical care to the plaintiff when he was detained in the Cumberland County Detention Center. Plaintiff was removed from a Greyhound bus traveling from New York City to Miami by the Fayetteville City Police at the request of personnel in Greyhound's Fayetteville bus terminal, who alleged he was either drunk or otherwise acting in a disruptive manner. While being removed from the bus and placed in a Fayetteville Police department vehicle, Plaintiff scuffled with the officer and fell over a curb while handcuffed. Plaintiff was processed that night into the Cumberland County Detention Center. In the morning, he requested medical care and was referred to Highsmith Rainey Hospital, where it was determined that, among other injuries, he had a broken collar bone. While the Sheriff's Office vigorously denies that it has any legal liability to the Plaintiff, the costs of continued defense of this action would likely exceed \$75,000 while any conceivable recovery against the Sheriff's Office would, because of the defense of sovereign immunity, be limited to the amount of the Sheriff's bond, \$25,000. The Plaintiff has agreed to settle for Twenty Five Thousand (\$25,000) Dollars. The costs associated with continued defense of this action would substantially exceed that amount. Plaintiff and his counsel have now signed the settlement agreement and Plaintiff has signed a comprehensive release and waiver of all claims.

**RECOMMENDATION:** File this memorandum with the minutes of this meeting as a record of settlement; authorize payment of \$25,000 in settlement of all claims and in exchange for a release of all claims against the County, the Sheriff's Office, and their personnel; and authorize the County Attorney to sign the settlement agreement, with no admission of liability.

## SETTLEMENT AGREEMENT

This SETTLEMENT AGREEMENT, made and entered into this the 19 day of April, 2007 by and between DAVID KAGAN (hereinafter PLAINTIFF) and the COUNTY OF CUMBERLAND and being made for the benefit of the following third-party beneficiaries of such agreement, including, EARL R. BUTLER, in his official capacity as Sheriff of Cumberland County, North Carolina, L.A. CHRISTIAN, individually, and in her official capacity as a Deputy Sheriff for Cumberland County, North Carolina, and WESTERN SURETY COMPANY, in its capacity as surety for the said Earl R. Butler (hereinafter referred to as "**RELEASED PARTIES**"):

### WITNESSETH

THAT WHEREAS, the parties to this Settlement Agreement are the PLAINTIFF and the County of Cumberland for the benefit of itself and three third-party beneficiaries, being three of the named Defendants in that civil action currently pending before the United States District Court for the Eastern District of North Carolina, Western Division, captioned: DAVID KAGAN, PLAINTIFF v S.C. MOSLEY, individually and in his official capacity, CITY OF FAYETTEVILLE, NORTH CAROLINA, a municipal corporation, EARL R. BUTLER, SHERIFF OF CUMBERLAND COUNTY, in his official capacity, L.A. CHRISTIAN, individually, and in her official capacity, WESTERN SURETY COMPANY, and GREYHOUND LINES, INC., a wholly owned subsidiary of LAIDLAW INTERNATIONAL, INC., DEFENDANTS, bearing file number 5:06CV 170-BR (hereinafter CIVIL ACTION); and

**WHEREAS, PLAINTIFF and the RELEASED PARTIES** have agreed to a settlement of the PLAINTIFF's claims against the **RELEASED PARTIES** only, upon the terms and conditions hereinafter set forth;

NOW THEREFORE, for and in consideration of the promises and obligations hereinafter made and undertaken, **PLAINTIFF and the RELEASED PARTIES** agree as follows:

1. Upon the execution of this agreement the **RELEASED PARTIES** shall pay, or cause to be paid, to the **PLAINTIFF** the sum of TWENTY FIVE THOUSAND DOLLARS (\$25,000.00). This sum shall be delivered and made payable to: Law Offices of Dale S. Morrison (Attorney for David Kagan), 4601 Park Road, Suite 620, Charlotte, NC 28209. That upon the delivery of the \$25,000.00 sum, **PLAINTIFF** shall execute and deliver to the **RELEASED PARTIES**, a Limited Release in the form attached hereto as Exhibit A.
2. Upon the entry of a Protective Order in regard to Discovery in the CIVIL ACTION, the **RELEASED PARTIES** shall timely and fully comply and deliver to **PLAINTIFF'S** counsel each of their Federal Rules of Civil Procedure, Rule 26(a) discovery disclosures and all discovery requests previously propounded by the **PLAINTIFF** to the **RELEASED PARTIES** in the CIVIL ACTION within fifteen (15) days. That such compliance by the **RELEASED PARTIES** shall be subject to the provisions of Rule 37 of the Federal Rules of Civil Procedure. **PLAINTIFF** and his counsel shall abide fully and completely by the terms of the protective order concerning the confidentiality, nondisclosure or restriction of the

**RELEASED PARTIES'** documents which may be subject to such protective order. Counsel for the **RELEASED PARTIES** shall promptly terminate and cancel all pending or ongoing discovery sought from **PLAINTIFF** which discovery was instituted by or on behalf of any of the **RELEASED PARTIES** except that with respect to the pending notices of deposition and subpoenas, if the remaining defendants wish to proceed then the parties shall proceed with the taking of the depositions without changing dates or times.

3. Upon compliance by the **RELEASED PARTIES** with the requirements of Paragraphs 1 and 2 above, the **PLAINTIFF** through counsel shall enter and file a voluntary dismissal *with prejudice* of **PLAINTIFF'S** claims against the **RELEASED PARTIES** only, in the CIVIL ACTION. Each party (**PLAINTIFF** and **RELEASED PARTIES**) shall bear his, her or its respective costs and attorneys fees. To the extent that a court order is required to dismiss the **RELEASED PARTIES** from the CIVIL ACTION, **PLAINTIFF'S** counsel and the **RELEASED PARTIES'** counsel shall cooperate in both a timely and good faith manner to obtain and effect such order. Nothing within this Settlement Agreement shall be construed as creating a right, defense, bar, remedy or other claim or action by those Defendants in the CIVIL ACTION who are not **RELEASED PARTIES** denominated under this Settlement Agreement.
4. The **RELEASED PARTIES** shall, subject to subpoena issued to their counsel of record in this action, make themselves, their employees and officers reasonably available to provide testimonial evidence in the CIVIL ACTION whether by deposition, testimony at trial, or both.
5. The **RELEASED PARTIES** warrant to the **PLAINTIFF** that they stand by, and will stand by, the denials contained in their answers to the **PLAINTIFF'S** complaint in the CIVIL ACTION; that such denials are of the material allegations of the paragraphs of the complaint to which such denials are addressed; and that such denials do not contain negative pregnant and are not otherwise evasive or misleading.
6. The **RELEASED PARTIES** warrant to the **PLAINTIFF** that the sums being paid pursuant to Paragraph 1 above represent the limits of liability of all bonds, insurance policies or other coverages available to cover the liability of any of the **RELEASED PARTIES** on the claims asserted by the **PLAINTIFF** in the CIVIL ACTION.
7. The **RELEASED PARTIES** warrant to the **PLAINTIFF** that they have made no agreements that would hinder, impair or delay the **PLAINTIFF'S** ability to pursue his claims against the other Defendants in the CIVIL ACTION or his ability to collect on any judgment he may recover against any of such other Defendants.

The foregoing contains the entire agreement between the parties, and no modification hereof shall be binding unless in writing and signed by the **PLAINTIFF** and such of the **RELEASED PARTIES** as may be affected by such modification.

The parties to this agreement represent by their signatures below that they have had full and timely opportunity to consult and discuss the terms of this Settlement Agreement with their respective counsel of record in the CIVIL ACTION. The parties represent by their signatures below that they enter this Settlement Agreement freely and voluntarily and have the requisite authority and approval to execute same.

**IN WITNESS WHEREOF**, the parties have hereunto set their hands and seals the day and year first above written.

*David Kagan*  
DAVID KAGAN  
DAVID KAGAN

*Dale S. Morrison*  
Dale S. Morrison  
Dale S. Morrison, Attorney for David Kagan

  
County of Cumberland  
County Attorney

## LIMITED RELEASE

The undersigned, DAVID KAGAN, for and in consideration of the sum of TWENTY FIVE THOUSAND DOLLARS (\$25,000.00) to me in hand paid, the receipt of which is hereby acknowledged, and other valuable consideration as hereinafter set forth, has released and discharged, and by these presents do, for myself, my heirs, executors, administrators, and assigns, hereby release and forever discharge EARL R. BUTLER, in his official capacity as Sheriff of Cumberland County, North Carolina, L.A. CHRISTIAN, individually, and in her official capacity as a Deputy Sheriff for Cumberland County, North Carolina, and WESTERN SURETY COMPANY, in its capacity as surety for the said Earl R. Butler (the aforementioned Earl R. Butler, L.A. Christian and Western Surety Company shall be referred to collectively as the "Released Parties"), AND NO OTHERS, from any and all claims, demands, damages, actions, causes of action, claims for relief or suits in law or in equity of whatsoever kind and nature, for and because of any matter or thing done or omitted to be done for and on account of any injuries or damages incurred by me as a result of my incarceration in the Cumberland County, North Carolina jail during the period April 23 -24, 2003, and all acts, omissions, events, incidents, transactions, occurrences, and circumstances, by or concerning the Released Parties or any agent, employee, or other persons or entities for whom the Released Parties are or may be liable, arising out of, connected to, or in any manner related to, or alleged or to which any reference is, was, or might have been made in any deposition, hearing, or proceeding held or conducted with respect to, or in any pleading, motion, or other paper served or filed in, the lawsuit described in this limited release in the following paragraph.

This limited release is given only to the Released Parties specified above, and only to the extent herein specified, and does not extend to any other persons or entities named as defendants in the lawsuit now pending before the United States District Court for the Eastern District of North Carolina, Western Division captioned: DAVID KAGAN, PLAINTIFF v S.C. MOSLEY, individually and in his official capacity, CITY OF FAYETTEVILLE, NORTH CAROLINA, a municipal corporation, EARL R. BUTLER, SHERIFF OF CUMBERLAND COUNTY, in his official capacity, L.A. CHRISTIAN, individually, and in her official capacity, WESTERN SURETY COMPANY, and GREYHOUND LINES, INC., a wholly owned subsidiary of LAIDLAW INTERNATIONAL, INC., DEFENDANTS, bearing file number 5:06CV170-BR.

That additional consideration for this Limited Release are the representations, promises and obligations made and undertaken by the Released Parties specified above in that Settlement Agreement made and entered into by David Kagan and the Released Parties hereto, dated contemporaneously with the date of this Limited Release, which representations, promises and obligations are a material consideration for this Limited Release and are a material inducement for the undersigned to execute this Limited Release.

The Limited Release of WESTERN SURETY COMPANY hereunder shall extend only to its obligations and liabilities as surety on the bond posted by the said Earl R. Butler pursuant to the provisions of North Carolina General Statute, Section 58-76-5, et seq and shall include any obligation to or for any deputy, employee, or the like, of Sheriff Earl R. Butler, arising out of or connected with the events, transactions or occurrences which may be the subject matter or this release. In the event Western Surety Company shall have any obligations or liabilities under the



provisions of any other bond, or other policy of insurance, in regard to the liability of any of the other defendants who have been named in the above civil federal court case, who may have such a bond or insurance policy issued to such defendant or which may provide coverage to any defendant who has been named in the referenced civil action, who are not specifically released hereby, then such obligations or liabilities of Western Surety Company are not released hereby and are specifically excluded from the scope and operation of this Limited Release.

I, David Kagan, the undersigned, understand, represent and agree that the payment being made pursuant hereto is not, and shall not be construed to be, an admission of liability on the part of any of the Released Parties named herein, their respective heirs, administrators, personal representatives, agents, employees, insurers, successors, or assigns, and that any such liability is expressly denied by the Released Parties.

I, David Kagan, the undersigned, further understand, represent and agree that the aforementioned payment and other valuable consideration is given by the Released Parties in settlement and compromise of doubtful and disputed claims and that this Limited Release, together with the Settlement Agreement referred to above, constitutes the entire agreement between the Released Parties and me, and that the terms and provisions hereof are contractual and not a mere recital.

I, David Kagan, the undersigned, understand, represent and agree that this Limited Release shall be binding upon me, my heirs, administrators, personal representatives, agents and assigns.

I, David Kagan, the undersigned, represent and agree that I have had full and timely opportunity to discuss this Limited Release and to consult with my attorneys before signing this document. Once I sign the Limited Release I am bound by its terms forever.

I, David Kagan, the undersigned, acknowledge that this Limited Release has been translated in my presence and carefully read to me, that I understand the contents, and that I sign this Limited Release as my own free and voluntary act.

This the 18 day of april 2007

  
\_\_\_\_\_  
DAVID KAGAN (SEAL)



ITEM NO. 1G(1)

## COUNTY of CUMBERLAND

Office of the County Attorney

May 4, 2007

**MEMORANDUM FOR BOARD OF COMMISSIONERS' MAY 21, 2007 AGENDA:**

TO: BOARD OF COMMISSIONERS

FROM: GRAINGER R. BARRETT, COUNTY ATTORNEY 

SUBJECT: APPROVAL OF SALE OF SURPLUS-COUNTY OWNED REAL PROPERTY ACQUIRED BY TAX FORECLOSURE

RES 314 MALONEY AVE LOTS 21-22  
(LOCATED ON MALONEY AVE. OFF GROVE ST.)  
PIN 0437-95-9834; CROSS CREEK TOWNSHIP

**BACKGROUND:** On or about October 26, 2005, the County acquired by tax foreclosure the above property. The amount currently owed on the foreclosure judgment including interest and cost for the property is \$4,737.07.

Syeda Chowdhury Gainey was the last and highest bidder offering to purchase the County's interest in the property for **\$9,900.00** and has deposited \$990.00 in the Finance Office. The tax value of the property is \$22,200.00.

This property is surplus to the needs of the County and, according to N.C.G.S. 153A-176 and N.C.G.S. 105-376, the County has the authority to sell such property. Management has reviewed this offer and it is now being submitted for the Board to consider whether or not to accept Ms. Gainey's bid. The property has been advertised and has received several bids; however, Ms. Gainey was the final and highest bidder. The bid period is now closed.

**RECOMMENDATION AND PROPOSED ACTION:** That the Board of Commissioners consider whether to accept the offer of Ms. Gainey to purchase the above property for the sum of **\$9,900.00**, plus costs, and authorize the Chairman to execute a deed upon receipt of the balance of the purchase price.

GRB/hnw  
Attachment



# Site Map

CROSS CREEK TOWNSHIP

314 MALONEY AVE

50 0 50 Feet



THE COUNTY OF CUMBERLAND AND ITS OFFICIALS MAKE NO WARRANTY, EXPRESS OR IMPLIED, CONCERNING THE ACCURACY, TIMELINESS, RESPONSIBILITY FOR INTERPRETING, AND APPLICATION OF THIS PRODUCT TO THE USER.

**COUNTY OF CUMBERLAND  
BUDGET REVISION REQUEST**

Budget Office Use	
Budget Revision No.	B07-345
Date Received	5/11/2007
Date Completed	

Fund No. 240 Agency No. 424 Organ. No. 4251  
 Organization Name: Injured Animal Stabilization Program

ITEM NO. 1H(1)

**REVENUE**

Revenue Source Code	Description	Current Budget	Increase (Decrease)	Revised Budget
9901	Fund Balance Appropriated	0	4,000	4,000
Total		0	4,000	4,000

**EXPENDITURES**

Object Code	Appr Unit	Description	Current Budget	Increase (Decrease)	Revised Budget
3204	753	Medical	2,168	4,000	6,168
Total			2,168	4,000	6,168

**Justification:**

Budget funds for anticipated veterinarian bills through June 30th.

Funding Source: State: \_\_\_\_\_ Federal: \_\_\_\_\_ Fund Balance: County: \_\_\_\_\_ New: \_\_\_\_\_ Other: \_\_\_\_\_  
 Other: \_\_\_\_\_ Fees: \_\_\_\_\_ Prior Year: \_\_\_\_\_

Submitted By: \_\_\_\_\_ Date: \_\_\_\_\_  
 Department Head  
 Reviewed By: KA [Signature] Date: 5-11-07  
 Budget Analyst  
 Reviewed By: Amyl Cannon Date: 5/16/07  
 Deputy Assistant County Mgr  
 Reviewed By: \_\_\_\_\_ Date: \_\_\_\_\_  
 Information Services

Approved By:	
_____	Date: _____
County Manager	
_____	Date: _____
Board of County Commissioners	
_____	Date: _____

**COUNTY OF CUMBERLAND  
BUDGET REVISION REQUEST**

Budget Office Use	Kelly Hills -02
Budget Revision No.	B07-341
Date Received	5/9/2007
Date Completed	

Fund No. 255 Agency No. 450 Organ. No. 450F  
 Organization Name: Kelly Hills Water & Sewer

ITEM NO. 1H(2)

**REVENUE**

*Pg 1 of 2*

Revenue Source Code	Description	Current Budget	Increase (Decrease)	Revised Budget
6689	Maintenance & Repair Water/Sewer Fees	0	400	400
9130	Transfer from Fund 010	0	24,504	24,504
Total		0	24,904	24,904

**EXPENDITURES**

Object Code	Appr Unit	Description	Current Budget	Increase (Decrease)	Revised Budget
3435	759	Maintenance & Repair Other	0	24,904	24,904
Total			0	24,904	24,904

**Justification:**

Transfer sales tax revenue and maintenance fees from the Kelly Hills capital project fund to the Kelly Hills maintenance fund.

Funding Source: State: \_\_\_\_\_ Federal: \_\_\_\_\_ County: \_\_\_\_\_ New: \_\_\_\_\_ Other: \_\_\_\_\_  
 Other: \_\_\_\_\_ Fees: \_\_\_\_\_ Prior Year: \_\_\_\_\_

Submitted By: \_\_\_\_\_ Date: \_\_\_\_\_  
 Department Head  
 Reviewed By: Todd Walker Date: 5/9/07  
 Budget Analyst  
 Reviewed By: Amyca Cannon Date: 5/10/07  
 Deputy/Assistant County Mgr  
 Reviewed By: \_\_\_\_\_ Date: \_\_\_\_\_  
 Information Services

<b>Approved By:</b>	
_____	Date: _____
County Manager	
_____	Date: _____
Board of County Commissioners	
_____	Date: _____

**COUNTY OF CUMBERLAND  
BUDGET REVISION REQUEST**

Budget Office Use	Kelly Hills -02A
Budget Revision No.	B07-341A
Date Received	5/9/2007
Date Completed	

Fund No. 010 Agency No. 450 Organ. No. 450B  
 Organization Name: Kelly Hills Water & Sewer

*Pg 2 of 2*

**REVENUE**

Revenue Source Code	Description	Current Budget	Increase (Decrease)	Revised Budget
---------------------	-------------	----------------	---------------------	----------------

Total

**EXPENDITURES**

Object Code	Appr Unit	Description	Current Budget	Increase (Decrease)	Revised Budget
3791	NBE	Construction	2,994,256	(24,504)	2,969,752
389U	NBF	Transfer to Fund 255	0	24,504	24,504

Total      2,994,256      -      2,994,256

**Justification:**

Transfer sales tax revenue and maintenance fees from the Kelly Hills capital project fund to the Kelly Hills maintenance fund.

Funding Source: State: \_\_\_\_\_ Federal: \_\_\_\_\_ Other: \_\_\_\_\_  
 Fund Balance: County: \_\_\_\_\_ New: \_\_\_\_\_ Prior Year: \_\_\_\_\_

Submitted By: \_\_\_\_\_ Date: \_\_\_\_\_

Reviewed By: *Ken* \_\_\_\_\_  
 Department Head  
 Budget Analyst

Reviewed By: *Amund Causton* \_\_\_\_\_  
 Deputy Assistant County Mgr

Reviewed By: \_\_\_\_\_  
 Information Services

Date: \_\_\_\_\_

Date: *5/9/07*

Date: *5/16/07*

Date: \_\_\_\_\_

<b>Approved By:</b>	
_____	Date: _____
County Manager	
_____	Date: _____
Board of County Commissioners	
_____	Date: _____

**COUNTY OF CUMBERLAND  
BUDGET REVISION REQUEST**

Budget Office Use	
Budget Revision No.	B07-342
Date Received	5/9/2007
Date Completed	

Fund No. 101 Agency No. 410 Organ. No. 4145  
 Organization Name: Register of Deeds

ITEM NO. 14(3)

**REVENUE**

Revenue Source Code	Description	Current Budget	Increase (Decrease)	Revised Budget
5205	Marriage Licenses	62,721	2,547	65,268
5305	Register of Deeds Fees	1,602,643	22,500	1,625,143

Total

**EXPENDITURES**

Object Code	Appr Unit	Description	Current Budget	Increase (Decrease)	Revised Budget
1827	021	Other Fringe	81,963	25,047	107,010
Total			81,963	25,047	107,010

**Justification:**

Revision in the amount of \$25,047 to budget additional revenue and expenditures anticipated for the remainder of the fiscal year.

**Funding Source:**

State: \_\_\_\_\_ Federal: \_\_\_\_\_ Fund Balance: \_\_\_\_\_ County: \_\_\_\_\_ New: \_\_\_\_\_ Other: \_\_\_\_\_  
 Other: \_\_\_\_\_ Fees: 25,047 Prior Year: \_\_\_\_\_

Submitted By: \_\_\_\_\_ Date: \_\_\_\_\_  
 Department Head  
 Reviewed By: Kelly Curtis Date: 5-9-07  
 Budget Analyst  
 Reviewed By: Amy Cannon Date: 5/16/07  
 Deputy/Assistant County Mgr  
 Reviewed By: \_\_\_\_\_ Date: \_\_\_\_\_  
 Information Services

<b>Approved By:</b>	
_____	Date: _____
County Manager	
_____	Date: _____
Board of County Commissioners	
_____	Date: _____

**COUNTY OF CUMBERLAND  
BUDGET REVISION REQUEST**

Budget Office Use	
Budget Revision No.	B07-340
Date Received	5/9/2007
Date Completed	

Fund No. 101 Agency No. 426 Organ. No. 4214  
 Organization Name: Cumberland Day Reporting Center

ITEM NO. 1H(4)

**REVENUE**

Pg 1 of 2

Revenue Source Code	Description	Current Budget	Increase (Decrease)	Revised Budget
4514	NC Community Corrections Reporting	235,486	21,700	257,186

Total

**EXPENDITURES**

Object Code	Appr Unit	Description	Current Budget	Increase (Decrease)	Revised Budget
3603	132	C.O. Vehicles	0	21,700	21,700
Total			0	21,700	21,700

**Justification:**

Revision in the amount of \$21,700 to recognize additional state reallocated funds per notification received April 23, 2007 for the purchase of van for transporting students.

Funding Source: State: 21,700 Federal: \_\_\_\_\_ County: \_\_\_\_\_ New: \_\_\_\_\_ Other: \_\_\_\_\_  
 Other: \_\_\_\_\_ Fees: \_\_\_\_\_ Prior Year: \_\_\_\_\_

Submitted By: \_\_\_\_\_ Date: \_\_\_\_\_  
 Department Head  
 Reviewed By: Keely Antrop Date: 5-9-07  
 Budget Analyst  
 Reviewed By: Amynah Cannon Date: 5/16/07  
 Deputy/Assistant County Mgr  
 Reviewed By: \_\_\_\_\_ Date: \_\_\_\_\_  
 Information Services

Approved By:	
_____	Date: _____
County Manager	
_____	Date: _____
Board of County Commissioners	
_____	Date: _____



**COUNTY OF CUMBERLAND  
REQUEST FOR CAPITAL OUTLAY**

Pg. 2 of 2

DEPT: Day Reporting ORGAN: 4214 FUND: 101 AGENCY: 424 ORGAN: 4214

ORGAN MGR: Callie Gardner PRIORITY: \_\_\_\_\_

DEPT HEAD SIGNATURE: \_\_\_\_\_

**DESCRIPTION OF REQUEST:**

New 12 passenger van

**JUSTIFICATION:**

for transportation of students

REVENUE		Amount	EXPENDITURE		Amount
Code	Funding Source		Object Code	Object Name	
	4514 State	21,700.00	3603	vehicles	21,700.00

Expected Results/Alternatives if NOT Approved:

Replacement Item:

Property #

Location

Disposition of Equipment

**COUNTY OF CUMBERLAND  
BUDGET REVISION REQUEST**

Budget Office Use	
Budget Revision No.	B07-349
Date Received	5/11/2007
Date Completed	

Fund No. 101 Agency No. 437 Organ. No. 4380  
 Organization Name: Welfare Other

ITEM NO. 14(5)

**REVENUE**

Revenue Source Code	Description	Current Budget	Increase (Decrease)	Revised Budget
5205	Marriage License	17,800	2,000	19,800

Total

**EXPENDITURES**

Object Code	Appr Unit	Description	Current Budget	Increase (Decrease)	Revised Budget
5602	273	NC Child Trust	17,800	2,000	19,800

Total                      17,800                      2,000                      19,800

**Justification:**

Revision in the amount of \$2,000 to budget additional revenue anticipated for the remainder of the fiscal year.

**Funding Source:**

State: \_\_\_\_\_ Federal: \_\_\_\_\_ County: \_\_\_\_\_ New: \_\_\_\_\_ Other: \_\_\_\_\_  
 Other: \_\_\_\_\_ Fees: \_\_\_\_\_ Prior Year: \_\_\_\_\_

**Fund Balance:**

Submitted By: \_\_\_\_\_ Date: \_\_\_\_\_  
 Department Head  
 Reviewed By: Kelly Autry Date: 5-11-07  
 Budget Analyst  
 Reviewed By: Amy Cannon Date: 5/16/07  
 Deputy Assistant County Mgr  
 Reviewed By: \_\_\_\_\_ Date: \_\_\_\_\_  
 Information Services

Approved By:	
_____	Date: _____
County Manager	
Board of County Commissioners	Date: _____

**COUNTY OF CUMBERLAND  
BUDGET REVISION REQUEST**

<b>Budget Office Use</b>	
Budget Revision No.	<u>B07-343</u>
Date Received	<u>5-10-07</u>
Date Completed	

Fund No. 112 Agency No. 43B Organ. No. 4348  
 Organization Name: MH-Substance Abuse Contracts

ITEM NO. 1H(6)a

**REVENUE**

Revenue Source Code	Description	Current Budget	Increase (Decrease)	Revised Budget
4251	Child Substance Abuse-State	0	45,069	45,069
Total		0	45,069	45,069

**EXPENDITURES**

Object Code	Appr Unit	Description	Current Budget	Increase (Decrease)	Revised Budget
3390	530	Contracted Services	958,617	45,069	1,003,686
Total			958,617	45,069	1,003,686

**Justification:**

Additional state funds to contract with Coastal Horizons for start-up and operations of adolescent substance abuse services.

Funding Source: State: X Federal: \_\_\_\_\_ County: \_\_\_\_\_ New: \_\_\_\_\_ Other: \_\_\_\_\_  
 Other: \_\_\_\_\_ Fees: \_\_\_\_\_ Prior Year: \_\_\_\_\_

Submitted By: <u>Donald M. Horn</u> Department Head	Date: <u>5-2-07</u>	Approved By:  _____ Date: _____ County Manager  Board of County Commissioners Date: _____
Reviewed By: <u>Kelly C. Crotty</u> Budget Analyst	Date: <u>5-10-07</u>	
Reviewed By: <u>Amyl C. Cannon</u> Deputy Assistant County Mgr	Date: <u>5/16/07</u>	
Reviewed By: _____ Information Services	Date: _____	

**COUNTY OF CUMBERLAND  
BUDGET REVISION REQUEST**

<b>Budget Office Use</b>	
Budget Revision No.	<u>B07-344</u>
Date Received	<u>5-10-07</u>
Date Completed	

Fund No. 112 Agency No. 43C Organ. No. 4343  
 Organization Name: MH - Devel. Disability Contracts

ITEM NO. 1H(6)b

**REVENUE**

Revenue Source Code	Description	Current Budget	Increase (Decrease)	Revised Budget
6206	Community Alternative Program Fees	45,000	66,500	111,500
Total		45,000	66,500	111,500

**EXPENDITURES**

Object Code	Appr Unit	Description	Current Budget	Increase (Decrease)	Revised Budget
3360	573	Other Services	67,175	66,500	133,675
Total			67,175	66,500	133,675

**Justification:**

Increase budget for medical supplies funded by Medicaid.

**Funding Source:**

State: \_\_\_\_\_ Federal: \_\_\_\_\_ County: \_\_\_\_\_ New: \_\_\_\_\_ Other: \_\_\_\_\_  
 Other: \_\_\_\_\_ Fees: X Prior Year: \_\_\_\_\_

**Fund Balance:**

Submitted By: Donald Hoover Date: 5-2-07  
 Department Head  
 Reviewed By: Kelly Austry Date: 5-10-07  
 Budget Analyst  
 Reviewed By: Amyd Cannon Date: 5/16/07  
 Deputy Assistant County Mgr  
 Reviewed By: \_\_\_\_\_ Date: \_\_\_\_\_  
 Information Services

<b>Approved By:</b>	
_____	Date: _____
County Manager	
_____	Date: _____
Board of County Commissioners	
_____	Date: _____

**COUNTY OF CUMBERLAND  
BUDGET REVISION REQUEST**

Budget Office Use	
Budget Revision No.	B07-347
Date Received	5/11/2007
Date Completed	

Fund No. 420 Agency No. 442 Organ. No. 4441  
 Organization Name: Parks and Recreation

ITEM NO. 14(7)

**REVENUE**

Revenue Source Code	Description	Current Budget	Increase (Decrease)	Revised Budget
1000	Taxes Current Year	1,855,672	175,000	2,030,672
1010	Motor Vehicle Tax	272,618	27,100	299,718
		2,128,290	202,100	2,330,390

**EXPENDITURES**

Object Code	Appr Unit	Description	Current Budget	Increase (Decrease)	Revised Budget
3390	766	Contracted Services	2,216,780	202,100	2,418,880
		Total	2,216,780	202,100	2,418,880

**Justification:**

Revision in the amount of \$202,100 to budget additional revenue anticipated for remainder of fiscal year.

**Funding Source:**

State: \_\_\_\_\_  
 Other: \_\_\_\_\_

Federal: \_\_\_\_\_  
 Fees: \_\_\_\_\_

**Fund Balance:**

County: \_\_\_\_\_ New: \_\_\_\_\_  
 Prior Year: \_\_\_\_\_

Other: 202,100

Submitted By: \_\_\_\_\_ Date: \_\_\_\_\_

Department Head

Reviewed By: Kelley Anthony Date: 5-11-07  
 Budget Analyst

Reviewed By: Amyd Cannon Date: 5/16/07  
 Deputy/Assistant County Mgr

Reviewed By: \_\_\_\_\_ Date: \_\_\_\_\_  
 Information Services

Approved By:	
_____	Date: _____
County Manager	
Board of County Commissioners	Date: _____

**COUNTY OF CUMBERLAND  
BUDGET REVISION REQUEST**

Budget Office Use	
Budget Revision No.	B07-348
Date Received	5/11/2007
Date Completed	

Fund No. 420 Agency No. 442 Organ. No. 4438  
 Organization Name: Recreation - Hope Mills

ITEM NO. 14(8)

**REVENUE**

Revenue Source Code	Description	Current Budget	Increase (Decrease)	Revised Budget
1000	Taxes Current Year	283,478	16,000	299,478
1010	Motor Vehicle Tax	31,742	2,000	33,742
		315,220	18,000	333,220

**EXPENDITURES**

Object Code	Appr Unit	Description	Current Budget	Increase (Decrease)	Revised Budget
3391	765	Contracted Services	315,200	18,000	333,200
		Total	315,200	18,000	333,200

**Justification:**

Revision in the amount of \$18,000 to budget additional revenue anticipated for remainder of fiscal year.

**Funding Source:**

State: \_\_\_\_\_ Federal: \_\_\_\_\_ County: \_\_\_\_\_ New: \_\_\_\_\_ Other: 18,000  
 Other: \_\_\_\_\_ Fees: \_\_\_\_\_ Prior Year: \_\_\_\_\_

**Fund Balance:**

Submitted By: \_\_\_\_\_ Date: \_\_\_\_\_

Department Head

Reviewed By: Kelly Centry Date: 5-11-07

Budget Analyst

Reviewed By: Amyd Cannon Date: 5/16/07

~~Deputy~~ Assistant County Mgr

Reviewed By: \_\_\_\_\_ Date: \_\_\_\_\_

Information Services

**Approved By:**

Date: \_\_\_\_\_

County Manager

Board of County  
Commissioners

Date: \_\_\_\_\_

**COUNTY OF CUMBERLAND  
BUDGET REVISION REQUEST**

Budget Office Use	
Budget Revision No.	B07-346
Date Received	5/11/2007
Date Completed	

Fund No. 106 Agency No. 470 Organ. No. 4704

Organization Name: School C.O. Category I - Buildings

ITEM NO. 1H(9)a

**REVENUE**

Revenue Source Code	Description	Current Budget	Increase (Decrease)	Revised Budget
9901	Fund Balance Appropriated	5,307,000	(159,000)	5,148,000
Total		5,307,000	(159,000)	5,148,000

**EXPENDITURES**

Object Code	Appr Unit	Description	Current Budget	Increase (Decrease)	Revised Budget
3836	458	School Capital Outlay - Category I	14,971,340	(159,000)	14,812,340
Total			14,971,340	(159,000)	14,812,340

**Justification:**

Revision in the amount of \$159,000 to reduce expenditures and related fund balance appropriated for certain Capital Outlay Category I items.

Funding Source: State: \_\_\_\_\_ Federal: \_\_\_\_\_ County: \_\_\_\_\_ New: \_\_\_\_\_ Other: \_\_\_\_\_  
 Other: \_\_\_\_\_ Fees: \_\_\_\_\_ Prior Year: \_\_\_\_\_

Submitted By: \_\_\_\_\_ Date: \_\_\_\_\_  
 Department Head  
 Reviewed By: Bob Tucker Date: 5/14/07  
 Budget Analyst  
 Reviewed By: Amund Cannon Date: 5/16/07  
 Deputy/Assistant County Mgr  
 Reviewed By: \_\_\_\_\_ Date: \_\_\_\_\_  
 Information Services

Approved By:	
_____	Date: _____
County Manager	
_____	Date: _____
Board of County Commissioners	
_____	Date: _____

**COUNTY OF CUMBERLAND  
BUDGET REVISION REQUEST**

Budget Office Use	
Budget Revision No.	B07-346A
Date Received	5/11/2007
Date Completed	

Fund No. 106 Agency No. 470 Organ. No. 4706  
 Organization Name: School C.O. Category II - Equipment

ITEM NO. 1H(9)6

**REVENUE**

Revenue Source Code	Description	Current Budget	Increase (Decrease)	Revised Budget
9901	Fund Balance Appropriated	1,344,000	79,897	1,423,897
Total		1,344,000	79,897	1,423,897

**EXPENDITURES**

Object Code	Appr Unit	Description	Current Budget	Increase (Decrease)	Revised Budget
3837	460	School Capital Outlay - Category II	4,159,000	79,897	4,238,897
Total			4,159,000	79,897	4,238,897

**Justification:**

Revision in the amount of \$79,897 to fund additional Capital Outlay Category II expenditures.

Funding Source: State: \_\_\_\_\_ Federal: \_\_\_\_\_ Fees: \_\_\_\_\_ Fund Balance: County: \_\_\_\_\_ New: \_\_\_\_\_ Other: \_\_\_\_\_  
 Prior Year: \_\_\_\_\_

Submitted By: \_\_\_\_\_ Date: \_\_\_\_\_  
 Department Head  
 Reviewed By: HA Bob Tucker Date: 5/14/07  
 Budget Analyst  
 Reviewed By: Amy Cannon Date: 5/16/07  
 Deputy Assistant County Mgr  
 Reviewed By: \_\_\_\_\_ Date: \_\_\_\_\_  
 Information Services

Approved By:	
_____	Date: _____
County Manager	
Board of County Commissioners	Date: _____



**COUNTY OF CUMBERLAND  
BUDGET REVISION REQUEST**

Budget Office Use	
Budget Revision No.	B07-346B
Date Received	5/11/2007
Date Completed	

Fund No. 106 Agency No. 470 Organ. No. 4706  
 Organization Name: School C.O. Category III - Vehicles

ITEM NO. 1H(9)c

**REVENUE**

Revenue Source Code	Description	Current Budget	Increase (Decrease)	Revised Budget
9901	Fund Balance Appropriated	75,000	(20,897)	54,103
Total		75,000	(20,897)	54,103

**EXPENDITURES**

Object Code	Appr Unit	Description	Current Budget	Increase (Decrease)	Revised Budget
3838	460	School Capital Outlay - Category III	425,000	(20,897)	404,103
Total			425,000	(20,897)	404,103

**Justification:**

Revision in the amount of \$20,897 to reduce expenditures and related fund balance appropriated for certain Capital Outlay Category III items.

**Funding Source:** State: \_\_\_\_\_ Federal: \_\_\_\_\_ Other: \_\_\_\_\_  
**Fund Balance:** County: \_\_\_\_\_ New: \_\_\_\_\_ Other: \_\_\_\_\_  
 Fees: \_\_\_\_\_ Prior Year: \_\_\_\_\_

Submitted By: \_\_\_\_\_ Date: \_\_\_\_\_  
 Department Head  
 Reviewed By: Bob Tucker Date: 5/14/07  
 Budget Analyst  
 Reviewed By: Amy Cannon Date: 5/16/07  
 Deputy Assistant County Mgr  
 Reviewed By: \_\_\_\_\_ Date: \_\_\_\_\_  
 Information Services

<b>Approved By:</b>	
_____	Date: _____
County Manager	
_____	Date: _____
Board of County Commissioners	
_____	Date: _____

**COUNTY OF CUMBERLAND  
BUDGET REVISION REQUEST**

Budget Office Use	
Budget Revision No.	<u>207-350</u>
Date Received	<u>5/3/07</u>
Date Completed	

Fund No. 101 Agency No. 422 Organ. No. 4200  
 Organization Name: Sheriff

ITEM NO. 1H(10)a

**REVENUE**

Revenue Source Code	Description	Current Budget	Increase (Decrease)	Revised Budget
<u>4640</u>	BulletProof Vest Partnership USDOJ Grant		6,552	
Total			6,552	

**EXPENDITURES**

Object Code	Appr Unit	Description	Current Budget	Increase (Decrease)	Revised Budget
2992	100	Dept Supplies	202,010	6,552	208,562
Total			202,010	6,552	208,562

**Justification:**

Recognize Revenue from US Dept of Justice Bulletproof Vest Partnership Award. Increase Expense Budget accordingly.

**Funding Source:**

State: \_\_\_\_\_  
 Other: \_\_\_\_\_

**Fund Balance:**

Federal: 6,552 County: \_\_\_\_\_ New: \_\_\_\_\_  
 Fees: \_\_\_\_\_ Prior Year: \_\_\_\_\_

Other: \_\_\_\_\_

Submitted By: Earl R. Butler Date: 5/3/07  
 Department Head

Reviewed By: Harold R. ... Date: 5/15/07  
 Budget Analyst

Reviewed By: Amy ... Date: 5/16/07  
 Deputy Assistant County Mgr

Reviewed By: \_\_\_\_\_ Date: \_\_\_\_\_  
 Information Services

Approved By:	
_____	Date: _____
County Manager	
Board of County Commissioners	Date: _____

**COUNTY OF CUMBERLAND  
BUDGET REVISION REQUEST**

Budget Office Use	
Budget Revision No.	B07-351
Date Received	5/10/2007
Date Completed	

Fund No. 101 Agency No. 422 Organ. No. 4200

Organization Name: Sheriff

ITEM NO. 14(10)B

**REVENUE**

Revenue Source Code	Description	Current Budget	Increase (Decrease)	Revised Budget
6460	Juvenile Crime Prevention Council	0	23,000	23,000
669E	Gang Violence In-kind	0	5,750	5,750
Total		0	28,750	28,750

**EXPENDITURES**

Object Code	Appr Unit	Description	Current Budget	Increase (Decrease)	Revised Budget
299A	100	Computer Hardware	500	1,500	2,000
2992	100	Department Supplies	208,562	3,500	212,062
2994	100	Misc Furniture & Equipment	113,185	3,700	116,885
2995	100	Software	0	10,300	10,300
3470	100	Travel	24,711	4,000	28,711
348B	100	Gang Violence In-kind	0	5,750	5,750
Total			346,958	28,750	375,708

**Justification:**

Recognize pass-through state grant funds from the NC Gang Violence grant.

**Funding Source:**

State: \_\_\_\_\_  
Other: \_\_\_\_\_

Federal: \_\_\_\_\_  
Fees: \_\_\_\_\_

**Fund Balance:**

County: \_\_\_\_\_ New: \_\_\_\_\_  
Prior Year: \_\_\_\_\_

Other: \_\_\_\_\_

Submitted By: \_\_\_\_\_

Date: \_\_\_\_\_

Reviewed By: Hannah Bar

Date: 5/15/07

Reviewed By: Amy Cannon  
Deputy Assistant County Mgr

Date: 5/16/07

Reviewed By: \_\_\_\_\_

Date: \_\_\_\_\_

Information Services

<b>Approved By:</b>	
_____	Date: _____
County Manager	
Board of County Commissioners	
_____	Date: _____

**COUNTY OF CUMBERLAND  
BUDGET REVISION REQUEST**

Budget Office Use	
Budget Revision No.	B07-351
Date Received	5/16/2007
Date Completed	

Fund No. 101 Agency No. 424 Organ. No. 4250  
 Organization Name: Animal Control

ITEM NO. 14(11)

**REVENUE**

Revenue Source Code	Description	Current Budget	Increase (Decrease)	Revised Budget
9901	Fund Balance Appropriated		38,091	

Total

**EXPENDITURES**

Object Code	Appr Unit	Description	Current Budget	Increase (Decrease)	Revised Budget
2510	127	Fuel Vehicles	24,000	8,291	32,291
3333	127	Spay/Neuter	25,000	3,000	28,000
3462	127	Rent Equipment	5,000	1,200	6,200
3480	127	Utilities	18,000	2,600	20,600
2201	127	Food & Provisions	8,500	13,000	21,500
3204	127	Medical	9,800	10,000	19,800
Total			90,300	38,091	128,391

**Justification:**

Revision in the amount of \$38,091 to appropriate fund balance to cover expenditures for the remainder of FY2007 fiscal year.

Funding Source: State: \_\_\_\_\_ Federal: \_\_\_\_\_ County: \_\_\_\_\_ New: 38,091.00 Other: \_\_\_\_\_  
 Other: \_\_\_\_\_ Fees: \_\_\_\_\_ Prior Year: \_\_\_\_\_

Submitted By: \_\_\_\_\_ Date: \_\_\_\_\_

Department Head

Reviewed By: Howard R. Rona Date: 5/16/07

Budget Analyst

Reviewed By: Amber Cannon Date: 5/16/07

Deputy/Assistant County Mgr

Reviewed By: \_\_\_\_\_ Date: \_\_\_\_\_

Information Services

Approved By:

Date: \_\_\_\_\_

County Manager

Board of County Commissioners

Date: \_\_\_\_\_

Charles C. Morris,  
Chair  
Town of Linden

Thomas J. Lloyd,  
Director

Donovan McLaurin,  
Vice-Chair  
Wade, Falcon & Godwin

Cecil P. Combs,  
Deputy Director

Garland C. Hostetter,  
Town of Spring Lake  
Harvey Cain, Jr.,  
Town of Stedman  
Patricia Hall,  
Town of Hope Mills

Clifton McNeill, Jr.,  
Roy Turner,  
Lori Epler,  
Sara E. Piland,  
Cumberland County

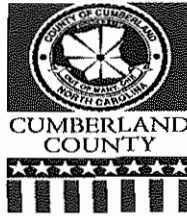

# COUNTY of CUMBERLAND

## Planning and Inspections Department

MAY 11, 2007

**MEMO TO:** CUMBERLAND COUNTY BOARD OF COMMISSIONERS

**FROM:** CUMBERLAND COUNTY JOINT PLANNING BOARD

**SUBJECT:** **P07-24:** REZONING OF .34 ACRES FROM R10 TO C1(P) OR TO A MORE RESTRICTIVE ZONING DISTRICT, AT 3639 BOONE TRAIL, OWNED BY JUDY L. (SUGGS) MORRIS.

**ACTION:** THE MEMBERS PRESENT AT THE APRIL 17, 2007 MEETING VOTED UNANIMOUSLY TO FOLLOW THE STAFF RECOMMENDATION AND APPROVE C1(P) PLANNED LOCAL BUSINESS DISTRICT.

**SITE INFORMATION:** **Area:** .34 acres; **Frontage & Location:** 100 feet on Boone Trail; **Depth:** 150 feet; **Jurisdiction:** County; **Adjacent Property:** No; **Current Use:** Residential; **Initial Zoning:** July 31, 1975 (Area 3); **Zoning Violation(s):** None; **Surrounding Zoning:** North-C1(P), R10, C1(P)/CU, Fayetteville city limits-C1A, East-R10, R6A, R6A/CU, C3, city limit-R10, South-R10, R6, R6A, C1(P), C(P), C3, and West-R10, R6, R6A, C1(P), C1(P)/CU; **Surrounding Land Use:** Vacant commercial, church, duplexes (3), car wash, mortgage company, CVP, manufactured home parks (2), hair salon, building company, pet boarding and grooming, and single family residential; **2010 Land Use Plan:** Low Density Residential; **Urban Services Area:** Yes; **Water/Sewer Availability:** PWC / PWC; **Soil Limitations:** None; **Subdivisions:** If rezoned, a site plan review will be required prior to any permits being issued; **Military Impact Area:** No; **Highway Plan:** Boone Trail is identified as a Major Thoroughfare. This proposal calls for a multi-lane facility with a 110 foot right-of-way (Priority 1). Road improvements are included in the 2007-2013 MTIP. Right-of-Way: unfunded, Construction: unfunded; **Average Daily Traffic Count (2004):** 6900 on Boone Trail.

**MINUTES OF APRIL 17, 2007:**

Mr. Combs reviewed the case information and stated that staff recommends approval of the C1(P) district based on the findings that although the C1(P) zoning district is not consistent with the 2010 Land Use Plan, which calls for Low Density Residential at this location, the subject property is located in an area of transition from residential to commercial zoning; the subject property is located on a Major Thoroughfare; and the C1(P) zoning district is in character with the current zoning of the general area. There are no other suitable zoning districts to be considered for this request.

**Mrs. Piland made a motion, seconded by Vice-Chair McLaurin, to follow the staff recommendation and approve case P07-24 as submitted. Unanimous approval.**

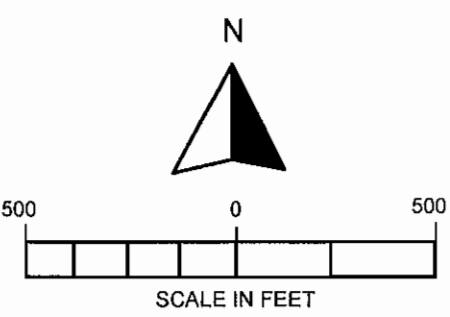
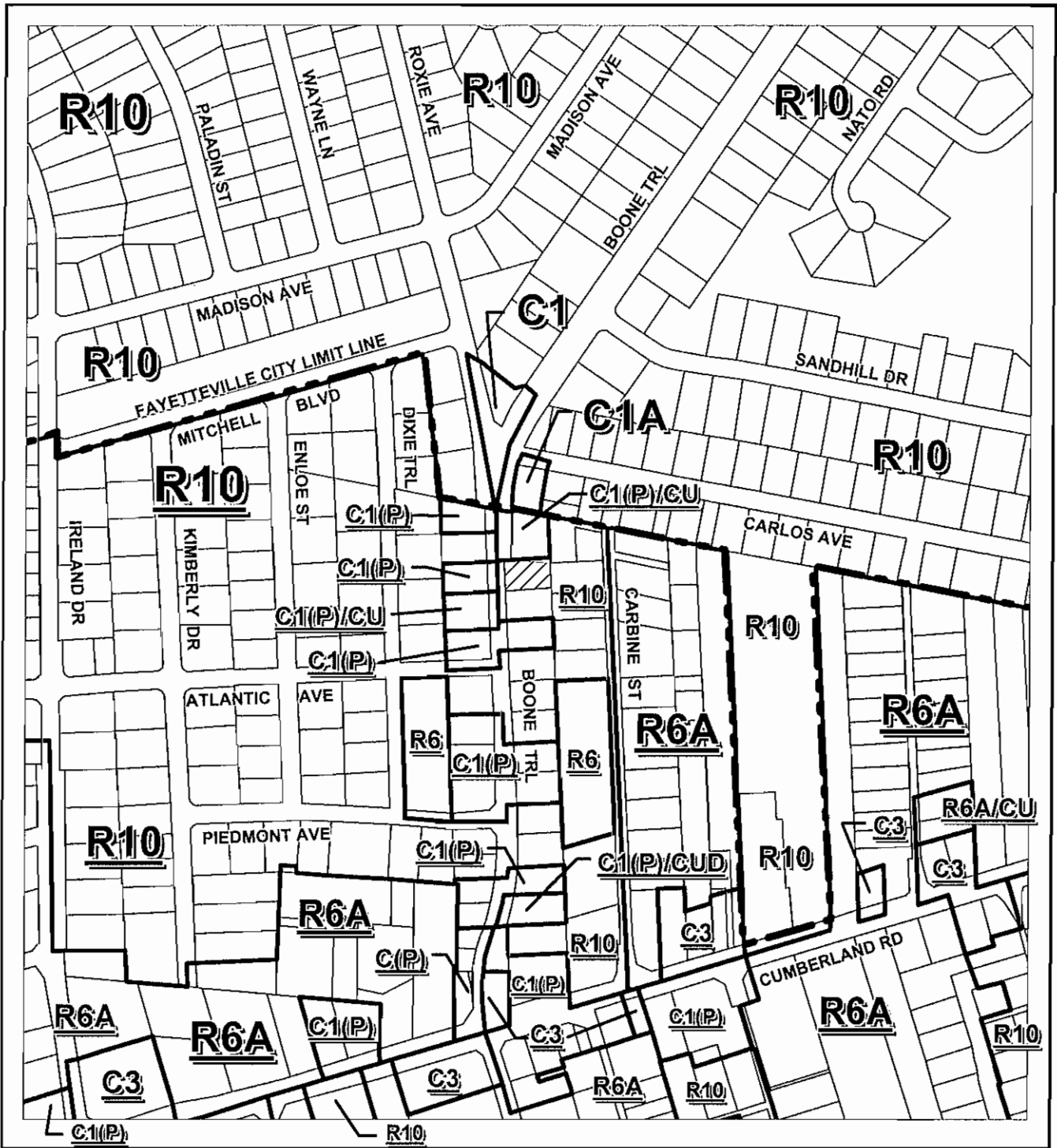

## REQUESTED REZONING R10 TO C1(P)

ACREAGE: 0.34 AC. +/-		HEARING NO: P07-24	
ORDINANCE: COUNTY		HEARING DATE	ACTION
PLANNING BOARD			
GOVERNING BOARD			

Charles C. Morris,  
Chair  
Town of Linden

Thomas J. Lloyd,  
Director

Donovan McLaurin,  
Vice-Chair  
Wade, Falcon & Godwin

Cecil P. Combs,  
Deputy Director

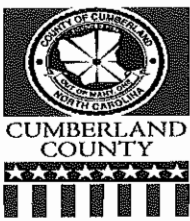

CUMBERLAND  
COUNTY  
**COUNTY of CUMBERLAND**  
*Planning and Inspections Department*

Clifton McNeill, Jr.,  
Roy Turner,  
Lori Epler,  
Sara E. Piland,  
Cumberland County

Garland C. Hostetter,  
Town of Spring Lake  
Harvey Cain, Jr.,  
Town of Stedman  
Patricia Hall,  
Town of Hope Mills

MAY 11, 2007

**MEMO TO:** CUMBERLAND COUNTY BOARD OF COMMISSIONERS  
**FROM:** CUMBERLAND COUNTY JOINT PLANNING BOARD  
**SUBJECT:** **P07-26:** REZONING OF A .24 ACRE PORTION OF A 26.18 ACRE TRACT, FROM A1 TO R15 OR TO A MORE RESTRICTIVE ZONING DISTRICT, LOCATED SOUTH OF SAND HILL ROAD, WEST OF TOWER ROAD, OWNED BY TERRY SPELL LAND DEVELOPMENT LLC.  
**ACTION:** THE MEMBERS PRESENT AT THE APRIL 17, 2007 MEETING VOTED UNANIMOUSLY TO FOLLOW THE STAFF RECOMMENDATION AND APPROVE R15 RESIDENTIAL DISTRICT.

**SITE INFORMATION:** **Area:** .24 acres; **Depth:** 105 feet; **Jurisdiction:** County; **Adjacent Property:** Yes; **Current Use:** Woodland; **Initial Zoning:** June 24, 1980 (Area 13); **Zoning Violation(s):** None; **Surrounding Zoning:** North-A1, R20, R20/DD/CUD, R15, R6A, East-A1, RR, South-A1, RR, R15, and West-A1, R15; **Surrounding Land Use:** Welding company, single family residential, vacant and woodland; **2010 Land Use Plan:** Low Density Residential; **Urban Services Area:** Yes; **Water/Sewer Availability:** PWC water available on South Forty Drive/Sewer not available; **Soil Limitations:** None; **School Capacity/Enrolled:** Gray's Creek Elementary 708/764, Gray's Creek Middle 614/495, Gray's Creek High 1087/1270; **Subdivisions:** This is a small portion of subdivision case 07-028 with preliminary subdivision approval; **Military Impact Area:** No; **Highway Plan:** No road improvements or new construction specified for this area; **Notes:** This staff-initiated rezoning is due to the .24 acre portion being inadvertently omitted from case P06-37.

**MINUTES OF APRIL 17, 2007:**

Mr. Combs reviewed the case information and stated that staff recommends approval of the R15 district based on the findings that the R15 zoning district is consistent with the 2010 Land Use Plan, which calls for Low Density Residential at this location; and rezoning this property will place the entire tract under one zoning classification. The rezoning of this property would rectify a staff mistake on Case P06-37. The other suitable zoning districts to be considered for this site are R40, R40A, R30, R30A, R20, and RR.

**Mrs. Piland made a motion, seconded by Vice-Chair McLaurin, to follow the staff recommendation and approve case P07-26 as submitted. Unanimous approval.**

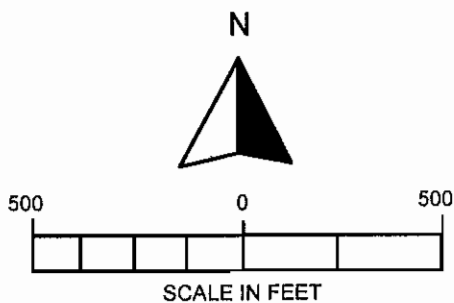
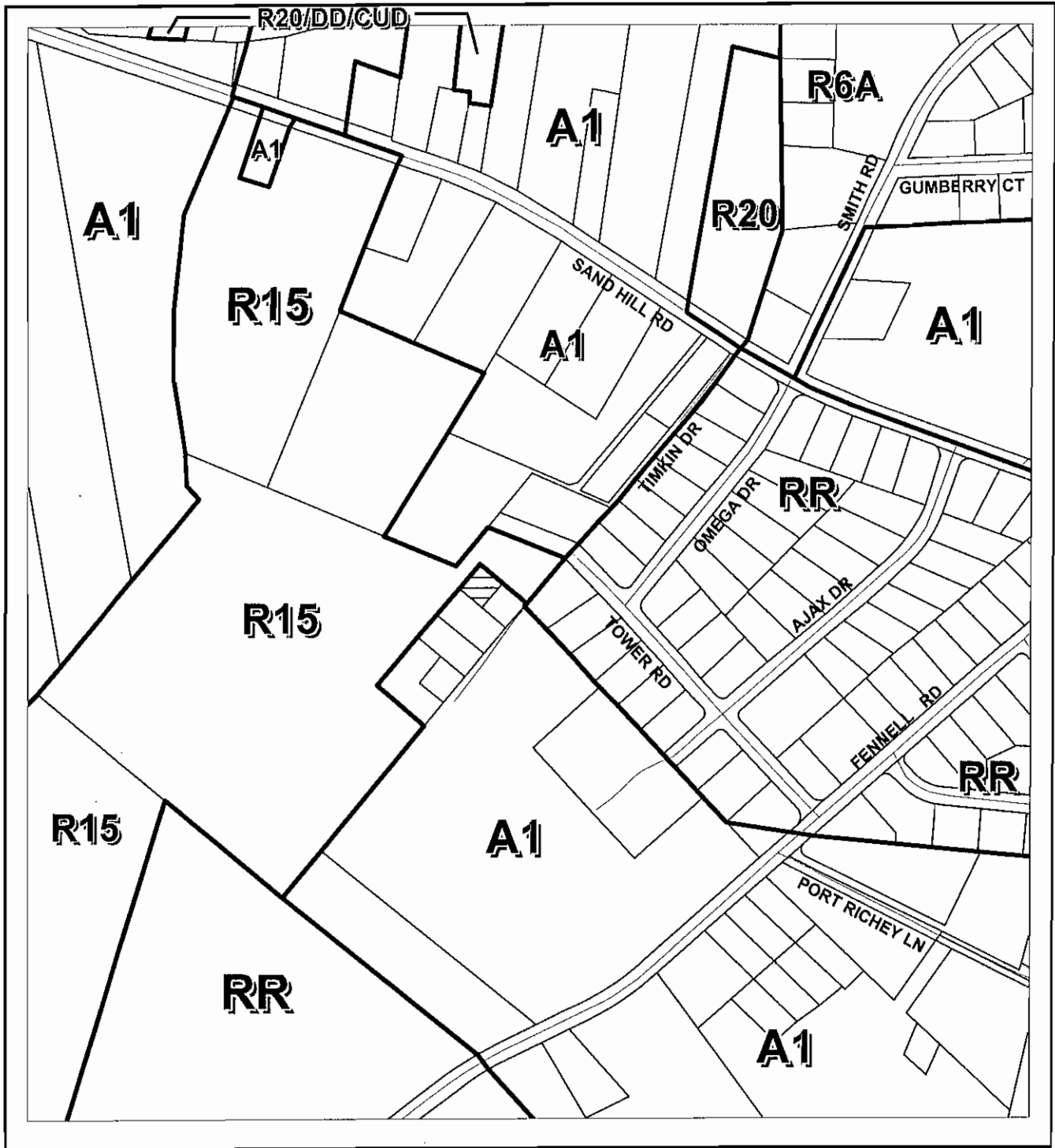

## REQUESTED REZONING A1 TO R15

<b>ACREAGE: 0.24 AC.+/-</b>	<b>HEARING NO: P07-26</b>	
<b>ORDINANCE: COUNTY</b>	<b>HEARING DATE</b>	<b>ACTION</b>
<b>PLANNING BOARD</b>		
<b>GOVERNING BOARD</b>		



Charles C. Morris,  
Chair  
Town of Linden

Donovan McLaurin,  
Vice-Chair  
Wade, Falcon & Godwin

Garland C. Hostetter,  
Town of Spring Lake  
Harvey Cain, Jr.,  
Town of Stedman  
Patricia Hall,  
Town of Hope Mills



# COUNTY of CUMBERLAND

## Planning and Inspections Department

Thomas J. Lloyd,  
Director

Cecil P. Combs,  
Deputy Director

Clifton McNeill, Jr.,  
Roy Turner,  
Lori Epler,  
Sara E. Piland,  
Cumberland County

MAY 11, 2007

**MEMO TO:** CUMBERLAND COUNTY BOARD OF COMMISSIONERS

**FROM:** CUMBERLAND COUNTY JOINT PLANNING BOARD

**SUBJECT:** **P07-27:** REZONING OF THREE PARCELS TOTALING 47.24 ACRES FROM R6A TO A1, LOCATED ON THE SOUTH SIDE OF TOM STARLING ROAD, AT INNISFREE PLACE, OWNED BY PATRICIA LEAHY.

**ACTION:** THE MEMBERS PRESENT AT THE APRIL 17, 2007 MEETING VOTED UNANIMOUSLY TO FOLLOW THE STAFF RECOMMENDATION AND APPROVE A1 AGRICULTURAL DISTRICT.

**SITE INFORMATION:** **Area:** 47.24 acres; **Frontage & Location:** 400 feet (total) on Tom Starling Road; **Depth:** 1413 feet (average); **Jurisdiction:** County; **Adjacent Property:** Yes; **Current Use:** Residential and woodland; **Initial Zoning:** June 24, 1980 (Area 13); **Zoning Violation(s):** None; **Surrounding Zoning:** North-RR, R15, R10, R6A, C1(P), M(P), M2, M2/CU, East-A1, RR, R6A, South-A1, R20, R20/DD/CUD, R15, and West-A1, R40, R40A, RR, R20, M(P); **Surrounding Land Use:** Manufactured home park, store and thrift store, auto shop, single family residential, vacant, farmland and woodland; **2010 Land Use Plan:** Medium Density Residential; **Urban Services Area:** Yes; **Water/Sewer Availability:** Well / Septic – PWC water available on Tom Starling Road; **Soil Limitations:** Yes – Tr (Torhunta and Lynn Haven soils) and Wo (Woodington loamy sand); **School Capacity/Enrolled:** Gallberry Farm Elementary 1032/886, South View Middle 922/822, Gray's Creek High 1087/1270; **Military Impact Area:** No; **Highway Plan:** Tom Starling Road is identified as a Major Thoroughfare. This proposal calls for a multi-lane facility (Priority 1). Road improvements are not included in the 2007-2013 MTIP; **Average Daily Traffic Count (2004):** 2800 on Tom Starling Road; **Notes:** Density minus 20% for roads: A1 – 18 lots, R6A – 274 lots.

**MINUTES OF APRIL 17, 2007:**

Mr. Combs presented the case information and stated that staff recommends approval of the A1 district based on the findings that although the A1 zoning district is not consistent with the 2010 Land Use Plan, which calls for Medium Density Residential at this location, the zoning district is more restrictive; and public utilities are not serving the subject property. The other suitable zoning districts to be considered for this site are R40, R40A, R30, R30A, R20, R20A, RR, R15, and R10.

**Mrs. Piland made a motion, seconded by Vice-Chair McLaurin, to follow the staff recommendation and approve case P07-27 as submitted. Unanimous approval.**

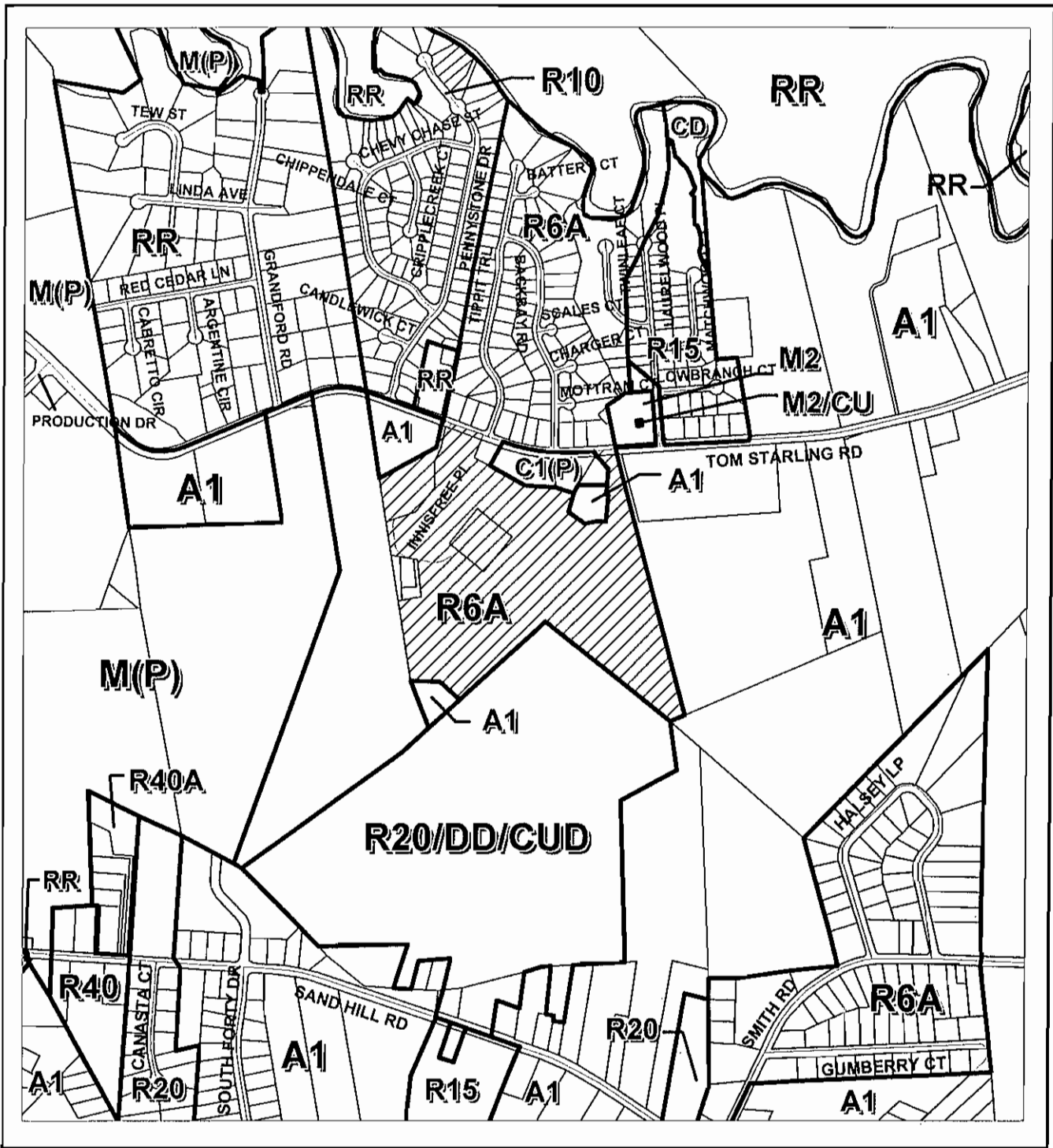

N



1000 0 1000

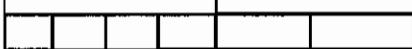

SCALE IN FEET

## REQUESTED REZONING: R6A TO A1

ACREAGE: 47.24 AC. +/-

HEARING NO: P07-27

ORDINANCE: COUNTY

HEARING DATE

ACTION

PLANNING BOARD

GOVERNING BOARD

Charles C. Morris,  
Chair  
Town of Linden

Donovan McLaurin,  
Vice-Chair  
Wade, Falcon & Godwin

Garland C. Hostetter,  
Town of Spring Lake  
Harvey Cain, Jr.,  
Town of Stedman  
Patricia Hall,  
Town of Hope Mills

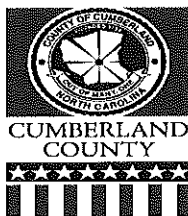

## COUNTY of CUMBERLAND

*Planning and Inspections Department*

Thomas J. Lloyd,  
Director

Cecil P. Combs,  
Deputy Director

Clifton McNeill, Jr.,  
Roy Turner,  
Lori Epler,  
Sara E. Piland,  
Cumberland County

MAY 11, 2007

MEMO TO: CUMBERLAND COUNTY BOARD OF COMMISSIONERS

FROM: CUMBERLAND COUNTY JOINT PLANNING BOARD

SUBJECT: **P07-28: INITIAL ZONING OF .92 ACRES TO RR, LOCATED ON THE WEST SIDE OF MISSION HILL ROAD, SOUTH OF OAK HAVEN ROAD, OWNED BY DAWN AND WILLIAM STOCK.**

ACTION: THE MEMBERS PRESENT AT THE APRIL 17, 2007 MEETING VOTED UNANIMOUSLY TO FOLLOW THE STAFF RECOMMENDATION AND APPROVE AS SUBMITTED.

**SITE INFORMATION:** Area: .92 acres; **Frontage & Location:** 209 feet on Mission Hill Road; **Depth:** 208 feet; **Jurisdiction:** County; **Adjacent Property:** No; **Current Use:** Residential; **Initial Zoning:** February 3, 1977 (Area 7); **Zoning Violation(s):** None; **Surrounding Zoning:** North-Hope Mills town limits-R10, R6, East-R10, town limit-R10, South-RR, R10, R6A, and West-RR, R6A; **Surrounding Land Use:** Single family residential and woodland; **2010 Land Use Plan:** Low Density Residential; **Municipal Influence Area:** Hope Mills; **Within Area Considered for Annexation:** This property was de-annexed from Hope Mills on June 30, 1995; **Urban Services Area:** Yes; **Water/Sewer Availability:** Well / Septic tank; **Soil Limitations:** None; **School Capacity/Enrolled:** C. Wayne Collier Elementary 588/599, Hope Mills Middle 761/686, South View High 1866/1800; **Military Impact Area:** No; **Highway Plan:** No road improvements or new construction specified for this area; **Notes:** Staff-initiated zoning due to not being initially zoned after de-annexation approved by the State legislature.

MINUTES OF APRIL 17, 2007:

Mr. Combs presented the case information and stated that staff recommends approval of the RR district based on the findings that although the RR zoning district is not consistent with the 2010 Land Use Plan, which calls for Suburban Density Residential at this location, the request is consistent with the current zoning of the area; and this request is a staff-initiated zoning due to the property not being initially zoned after de-annexation by the State legislature on June 30, 1995. There are no other suitable zoning districts to be considered for this site.

**Mrs. Piland made a motion, seconded by Vice-Chair McLaurin, to follow the staff recommendation and approve case P07-28 as submitted. Unanimous approval.**

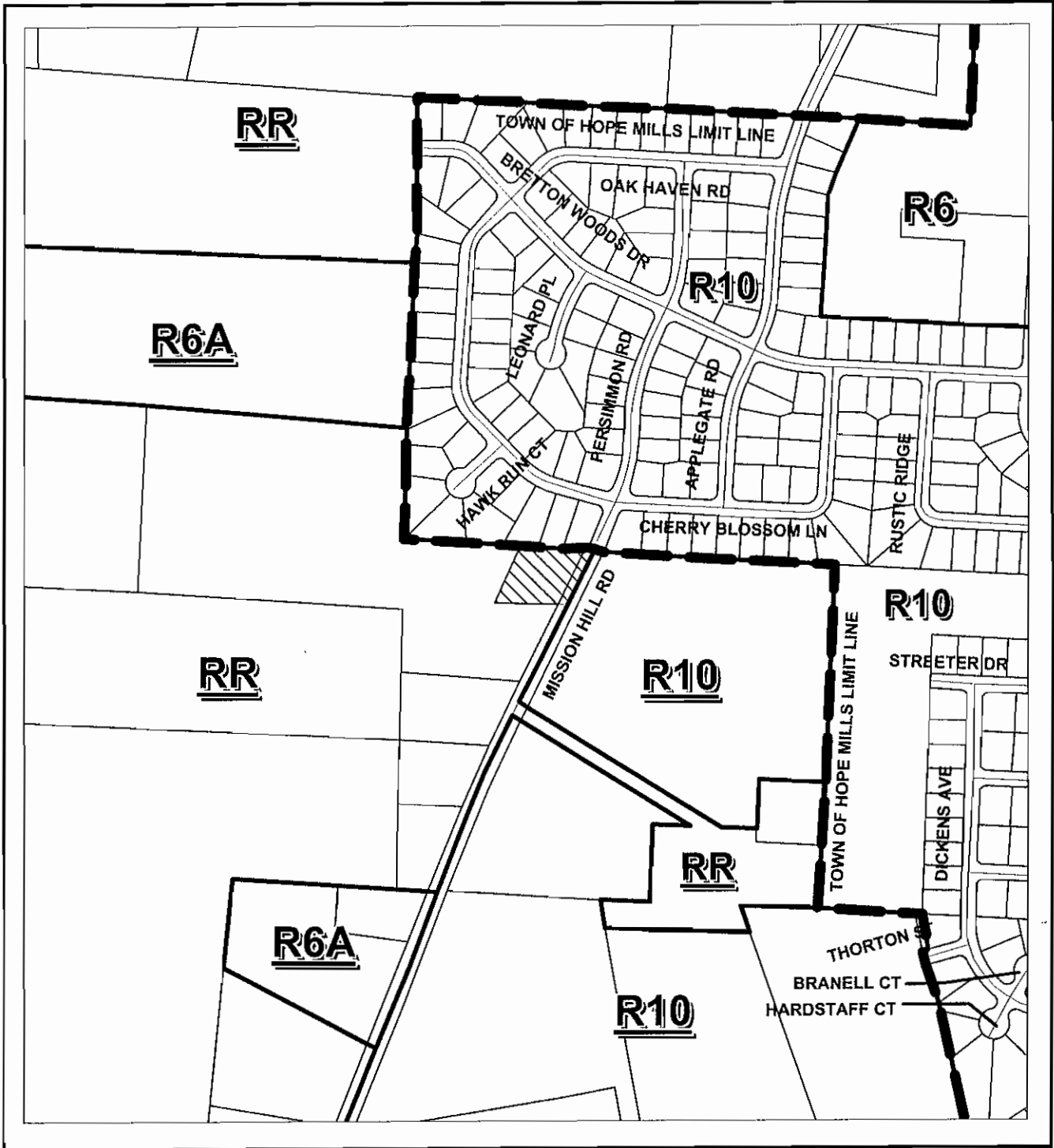

N



500 0 500



SCALE IN FEET

## INITIAL ZONING: TO RR

ACREAGE: 0.92 AC.+/-

HEARING NO: P07-28

ORDINANCE: COUNTY

HEARING DATE

ACTION

PLANNING BOARD

GOVERNING BOARD

Charles C. Morris,  
Chair  
Town of Linden

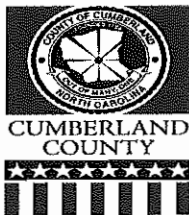

Thomas J. Lloyd,  
Director

Donovan McLaurin,  
Vice-Chair  
Wade, Falcon & Godwin

Cecil P. Combs,  
Deputy Director

Garland C. Hostetter,  
Town of Spring Lake  
Harvey Cain, Jr.,  
Town of Stedman  
Patricia Hall,  
Town of Hope Mills

## COUNTY of CUMBERLAND

*Planning and Inspections Department*

Clifton McNeill, Jr.,  
Roy Turner,  
Lori Epler,  
Sara E. Piland,  
Cumberland County

MAY 11, 2007

MEMO TO: CUMBERLAND COUNTY BOARD OF COMMISSIONERS

FROM: CUMBERLAND COUNTY JOINT PLANNING BOARD

SUBJECT: **P07-30: REZONING OF .28 ACRES FROM R10 TO O&I(P) OR TO A MORE RESTRICTIVE ZONING DISTRICT, AT 1449 E. MANCHESTER ROAD, SUBMITTED BY COLON L. JAMES JR, OWNED BY MALCOLM JAMES.**

ACTION: THE MEMBERS PRESENT AT THE APRIL 17, 2007 MEETING VOTED UNANIMOUSLY TO FOLLOW THE STAFF RECOMMENDATION AND APPROVE AS SUBMITTED.

**SITE INFORMATION:** Area: .28 acres; **Frontage & Location:** .80 feet on East Manchester Road; **Depth:** 182 feet; **Jurisdiction:** County; **Adjacent Property:** No; **Current Use:** Residential; **Initial Zoning:** January 7, 1977 (Area 11); **Zoning Violation(s):** None; **Nonconformities:** The side yard is currently legal, nonconforming due to dimensional requirements and if rezoned, the nonconformity will be increased by an additional 5 feet; **Surrounding Zoning:** North-RR, R10, R6A, C1(P), East-RR, R10, C1(P), South-CD, RR, R10, R6A, C1(P), and West-RR, R10, R6A; **Surrounding Land Use:** Dry cleaning and sewing business, water tower, meat market (3), fruit and vegetable stand, church, substation, single family residential and vacant land; **Spring Lake Area Detailed Land Use Plan:** Low Density Residential; **Municipal Influence Area:** Spring Lake; **Urban Services Area:** Yes; **Water/Sewer Availability:** Well/ Septic Tank; **Soil Limitations:** None; **Subdivisions:** If approved, a site plan review will be required prior to any development; **Military Impact Area:** Yes; **Ft Bragg/Pope AFB:** 1-mile buffer area -- Pope AFB has no objections to this case; **Highway Plan:** No road improvements or new construction specified for this area; **Average Daily Traffic Count (2004):** 5200 on East Manchester Road.

### MINUTES OF APRIL 17, 2007

Mr. Combs reviewed the site information and stated that staff recommends approval of the O&I(P) district based on the findings that although the O&I(P) zoning district is not consistent with the 2010 Land Use Plan, which calls for Low Density Residential at this location, the district would act as a buffer from the commercial property to the east; and the subject property is located on a Major Thoroughfare. There are no other suitable zoning districts to be considered for this site.

**Mrs. Piland made a motion, seconded by Vice-Chair McLaurin, to follow the staff recommendation and approve case P07-30 as submitted. Unanimous approval.**



Charles C. Morris,  
Chair  
Town of Linden

Donovan McLaurin,  
Vice-Chair  
Wade, Falcon & Godwin

Garland C. Hostetter,  
Town of Spring Lake  
Harvey Cain, Jr.,  
Town of Stedman  
Patricia Hall,  
Town of Hope Mills



**COUNTY of CUMBERLAND**  
*Planning and Inspections Department*

Thomas J. Lloyd,  
Director

Cecil P. Combs,  
Deputy Director

Clifton McNeill, Jr.,  
Roy Turner,  
Lori Epler,  
Sara E. Piland,  
Cumberland County

MAY 11, 2007

**MEMO TO:** CUMBERLAND COUNTY BOARD OF COMMISSIONERS  
**FROM:** CUMBERLAND COUNTY JOINT PLANNING BOARD  
**SUBJECT:** **P07-20:** REZONING OF THREE PARCELS TOTALING 43.36 ACRES FROM A1 TO R30 OR TO A MORE RESTRICTIVE ZONING DISTRICT, LOCATED SOUTH OF DUNN ROAD, EAST OF RINGWOOD DRIVE, SUBMITTED BY TAMMY CAIN BARRY, OWNED BY CAIN BUILDERS, INC.  
**ACTION:** THE MEMBERS PRESENT AT THE APRIL 17, 2007 MEETING VOTED UNANIMOUSLY TO FOLLOW THE STAFF RECOMMENDATION AND APPROVE R40 RESIDENTIAL DISTRICT.

**SITE INFORMATION:** **Area:** 43.36 acres; **Depth:** 1,830 feet; **Jurisdiction:** County; **Adjacent Property:** Yes; **Current Use:** Agricultural; **Initial Zoning:** April 25, 1979 (Area 8); **Zoning Violation(s):** None; **Surrounding Zoning:** North-A1, R40A, RR, East-A1, R40, RR, South-A1, RR, and West-A1, R30A, RR, HS(P); **Surrounding Land Use:** Single family residential, woodland and farmland; **Eastover Study Area Detailed Land Use Plan:** One-Acre Residential; **Urban Services Area:** Yes; **Eastover Sanitary District:** This property should not be zoned R30, which is contrary to the Eastover Land Use Plan. Water is available to support A1 but not R30. Sewer is not available here; **Soil Limitations:** Yes – Cf (Cape Fear loam) and Ro (Roanoke and Wahee loams); **School Capacity/Enrolled:** Sunnyside Elementary 335/245, Mac Williams Middle 1162/1274, Cape Fear High 1489/1400; **Subdivisions:** A subdivision revision/review may be required prior to any permits being issued on this development; **Military Impact Area:** No; **Highway Plan:** No road improvements or new construction specified for this area; **Notes:** Density minus 20% for roads: A1 – 17 lots; R40 – 37 lots; R30 – 50 lots.

MINUTES OF APRIL 17, 2007:

Mr. Combs reviewed the case information and stated that staff recommends denial of the R30 district and approval of the R40 district based on the findings that the R40 zoning district is consistent with the Eastover Land Use Plan, which calls for One-Acre Residential lots at this location; the R40 district is consistent with the character and lot sizes in the general area; and there are hydric soils on the property. The applicant sent an e-mail to indicate they are in agreement with this staff recommendation. There are no other suitable zoning districts to be considered for this request.

The Public Hearing opened.

Tammy Barry spoke in favor of the request. She stated that she and her brother were going to build a nice subdivision and that the lots would be from 1 to 2 acres in size. The requested zoning would allow for maximum lot development and the property would be served by a state maintained road.

Morgan Johnson spoke in opposition of the R30. He distributed pictures of the area showing standing water and swampy conditions. He stated that as Chairman of the Eastover Sanitary District he would concur with the staff recommendation of R40.

Janet Idol spoke in opposition and distributed photos to the Board to show her concern with drainage problems in the area. She stated that septic tanks were not suitable for this area. She requested that any rezoning allow for as small a number of lots as possible.

Tammy Barry spoke in rebuttal and stated that she was aware of drainage and runoff concerns and that those issues would be addressed during development.

The Public Hearing closed.

Mrs. Piland stated that she is aware of the drainage and runoff problems in the area, as she lives within one mile of the proposed subdivision. She stated that R40 is more appropriate for the area and is in agreement with the Eastover Land Use Plan. She stated that any development there would still be difficult without water and sewer.

Vice-Chair McLaurin advised the Board that he was also familiar with the area and that a majority of the property is on a sand ridge. The ridge is where the houses will be built. He stated that a ditch on the property does fill with water but the ridge area is certainly appropriate for houses. Vice-Chair McLaurin stated that soils should have no problem sustaining septic tanks.

**Mr. Turner made a motion, seconded by Mr. Cain, to follow the staff recommendation and approve R40. Unanimous approval.**



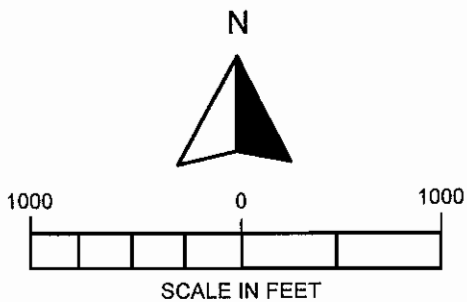
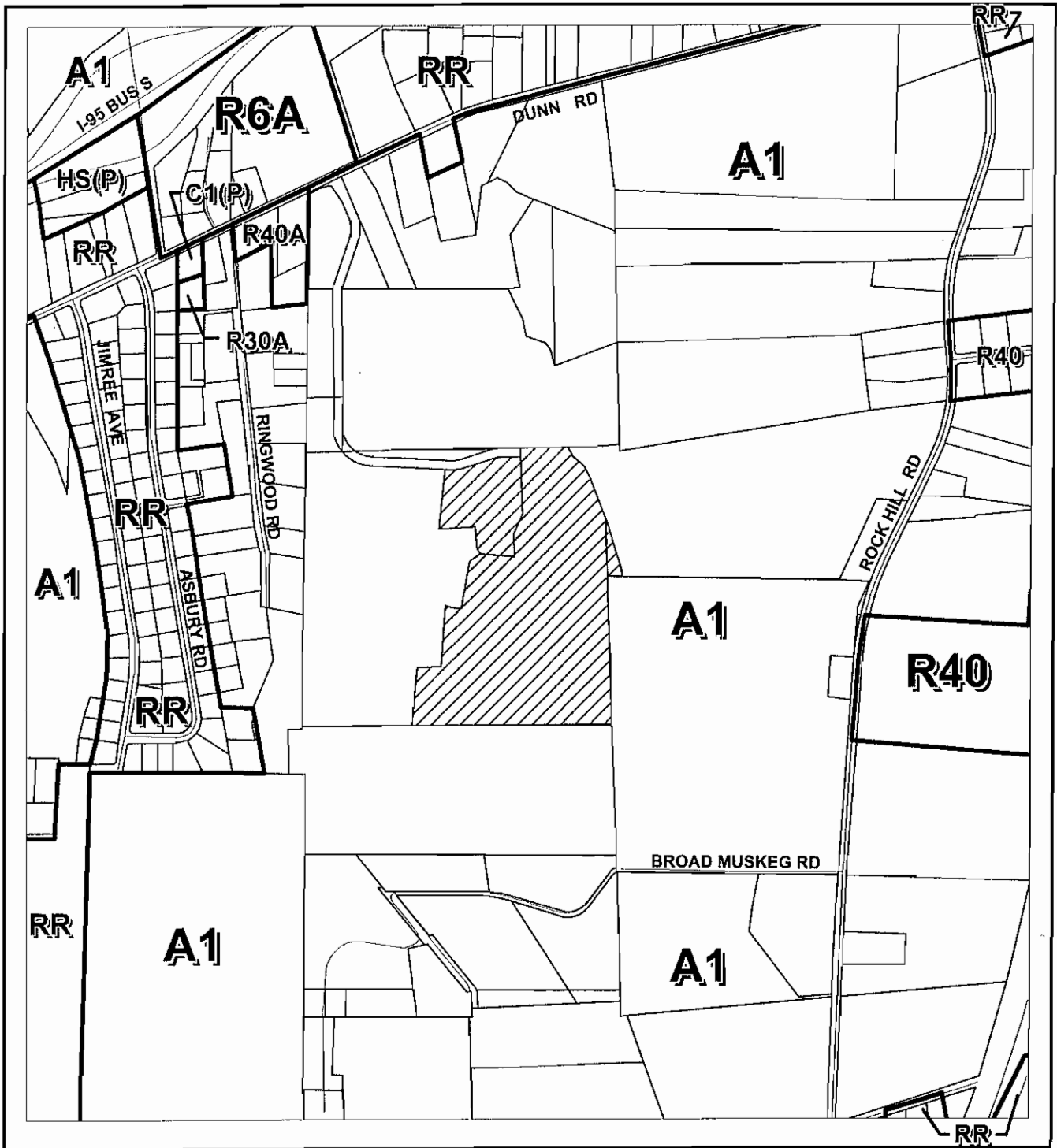

## REQUESTED REZONING A1 TO R30

<b>ACREAGE: 43.36 AC.+/-</b>		<b>HEARING NO: P07-20</b>	
ORDINANCE: COUNTY	HEARING DATE	ACTION	
PLANNING BOARD			
GOVERNING BOARD			

PIN: 0458-70-7236  
 PIN: 0457-89-0532  
 PIN: 0457-89-5961

Charles C. Morris,  
Chair  
Town of Linden

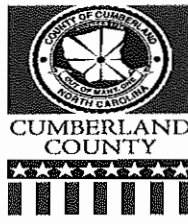

Thomas J. Lloyd,  
Director

Donovan McLaurin,  
Vice-Chair  
Wade, Falcon & Godwin

Cecil P. Combs,  
Deputy Director

Garland C. Hostetter,  
Town of Spring Lake  
Harvey Cain, Jr.,  
Town of Stedman  
Patricia Hall,  
Town of Hope Mills

# COUNTY of CUMBERLAND

*Planning and Inspections Department*

Clifton McNeill, Jr.,  
Roy Turner,  
Lori Epler,  
Sara E. Piland,  
Cumberland County

MAY 11, 2007

**MEMO TO:** CUMBERLAND COUNTY BOARD OF COMMISSIONERS

**FROM:** CUMBERLAND COUNTY JOINT PLANNING BOARD

**SUBJECT:** **P07-04:** REZONING OF 44.32+/- AC FROM A1 TO R15/DENSITY DEVELOPMENT/CONDITIONAL USE DISTRICT & PERMIT OR TO A MORE RESTRICTIVE ZONING DISTRICT, LOCATED ON THE WEST SIDE OF OLD VANDER ROAD, NORTHWEST OF SIMMONS CARTER ROAD, OWNED BY GERTRUDE V. HARRIS.

**ACTION:** MEMBERS PRESENT AT THE APRIL 17, 2007 MEETING VOTED UNANIMOUSLY TO FOLLOW THE STAFF RECOMMENDATIONS TO APPROVE R40/DENSITY DEVELOPMENT/CONDITIONAL USE DISTRICT AND APPROVE THE CONDITIONAL USE PERMIT.

**SITE INFORMATION:** **Area:** 44.32 acres (by deed) / Surveyor's acreage: 42.532+/- acres  
**Frontage & Location:** 2,640 feet on Old Vander Road; **Depth:** 700 foot (average);  
**Jurisdiction:** County; **Adjacent Property:** Yes; **Current Use:** Vacant; **Initial Zoning:** September 14, 1979 (Area 9); **Zoning Violation(s):** None; **Surrounding Zoning:** North and East-A1, RR, South-A1, R40, R6A, and West-A1; **Surrounding Land Use:** Upholstery business, day care, single family residential, and farmland; **2010 Land Use Plan:** Farmland; **Urban Services Area:** No; **Water/Sewer Availability:** Well / Septic – no PWC utilities currently available; **Soil Limitations:** Yes – Leon sand (Le) and Woodington loamy sand (Wo)  
**School Capacity/Enrolled:** Seabrook Elementary 340/364, Mac Williams Middle 1274/1170, Cape Fear High 1400/1439; **Military Impact Area:** No; **Highway Plan:** No road improvements or new construction are specified for this area; **Average Daily Traffic Count (2004):** 1,200 on Old Vander Road; **Notes:** Density minus 3.229 for Roads: A1 - 20 lots, R40 – 44 lots, R30 – 59 lots, R20 – 89 lots, R15 – 119 lots

### Application Information

The applicant has revised the original application and is now requesting a density of R40; this revision is more restrictive than the original request.

1. Proposed Use: Gated residential community with attached sundecks, recreational center, tennis courts, swimming pools, bike trail, walking trail, playground, landscaping, small retention pond for ducks, and green energy solar plant and water pumping station. .
2. Number of Lots Proposed: 42 (42 lots allowed)

**Ordinance Required Conditions for Permit**

1. The owner/developer(s) of these lots must obtain detailed instructions on provisions of the County Zoning Ordinance and permits required to place any structure within this development from the County Code Enforcement Section, Room 101 in the Historic Courthouse at 130 Gillespie Street. For additional information, the developer should contact a Code Enforcement Officer
2. Connection to public water and sewer is required, the Public Works Commission (PWC) must approve water and sewer plans prior to application for any permits. (Note: If it is determined by the PWC that public water and sewer extension is not available and/or feasible, the Joint Planning Board's recommendation of approval of this application is to be considered as the Board granting an exception from the extension requirements as authorized in Section 4.3.d, County Subdivision Ordinance.)
3. The developer must provide the Code Enforcement Section with an approved state sedimentation and erosion control plan (S&E) prior to any application for permits. If any retention/detention basins are required for state approval of this plan, then five copies of a revised plan showing the location of the basin(s) must be submitted and approved by Planning & Inspections prior to application for any permits.
4. The developer must provide a site-specific address and tax parcel number at the time of building/zoning permit application.
5. *Certificate of Occupancy* will not be issued until a Code Enforcement Officer inspects the site and certifies that the site is developed in accordance with the approved plans.

**Site-Related:**

6. The developer is required to submit to Land Use Codes, three copies of the legal documents specifically designating responsibility for maintenance and keep of recreational facilities, community center, open space and all other common areas through an owners' association for this development. These documents must be approved by the County Attorney prior to any permit application and/or the sale of or submission for final plat approval of any lot or unit within this development.
7. All setbacks along the periphery of this development shall meet the dimensional requirements of the adjacent zoning district(s).
8. All applicable uses, dimensions and other related provisions of the County Subdivision and Zoning Ordinances for the R40 zoning district must be complied with, as applicable.
9. This conditional approval is not approval of any subdivision entrance signs. A site plan with the sign dimensions annotated must be submitted to Land Use Codes prior to application for any permits for any freestanding signs.
10. Sections 4.1.d, "Required Drainage"; 4.3.g, "Fire Hydrants", and 4.3.h, "Underground Utilities", of the County Subdivision Ordinance must be adhered to.
11. The developer must obtain a curb-cut permit from the NC Department of Transportation (NCDOT) for the intersection with SR 2013 (Old Vander Road).
12. The NC Department of Transportation (NCDOT) may require turn lanes to be installed.

13. All lighting is required to be directed internally within this development and comply with the provisions of §1102 M, Outdoor Lighting, County Zoning Ordinance.
14. A solid buffer must be provided and maintained in accordance with the provisions of §803.E, County Zoning Ordinance.
15. All dumpster, garbage, and utility areas shall be located on concrete pads and screened on a minimum of three sides.

**Plat-Related:**

16. A 10' x 70' sight distance easement is required where the private road intersects with SR 2013 (Old Vander Road) and must be reflected on the final plat.
17. The street name signs, in compliance with the County Street Sign Specifications, must be installed prior to final plat approval. The developer should contact E911 Street Naming/Signs for inquiries regarding the County's policy for street sign installation or, if the sign is commissioned from a private source, to schedule an inspection of the street sign(s). Land Use Codes must receive notice of agreement with the Street Naming & Addressing Section for sign installation or of satisfactory inspection prior to the approval of the final plat.
18. The developer is to contact E911 Street Naming and Addressing regarding the process of acquiring "approved" street names and the approved street names must be reflected on the final plat when any portion of this development is submitted for final approval. (Note: Street name approval can take up to ten working days.)
19. The builder/developer shall provide the buildable envelopes on the final plat: providing a five-foot maintenance easement along each side of all common internal lines with all other applicable setbacks being provided for, **or** at the time of permit application, the individual plot plans for each individual residential lot must be approved by Land Use Codes prior to issuance of any permits.
20. Any/All easements shall be reflected on the final plat and labeled as to type of easement, reference number for document creating the easement, and the name of the agency, individual, etc. who holds the easement.
21. The developer shall provide for an inspection of the private street(s) by a registered engineer or registered surveyor upon completion of construction of the private street(s) and related facilities, including drainage ways. A statement, affixed with the engineer/surveyor's seal, certifying that all private street(s) and related facilities are designed and constructed in accordance with the requirements of Section 4.2, County Subdivision Ordinance, and that all such facilities are adequate to serve the development, must be submitted to Land Use Codes prior to final plat approval or release of any construction guarantees as allowed under Section 2.6, County Subdivision Ordinance.
22. A 25' right-of-way radius is required at all intersections and must be reflected on the final plat.
23. The notarized signature(s) of all current tax record owner(s) and notary certifications appear on the final plat when submitted for final approval.
24. The developer is reminded that the improvements must be in place or that final plat approval will only be granted in accordance with Section 2.6 b, c, or d, County Subdivision Ordinance. (Note: Once the improvements are in place, the developer is responsible for contacting Peggy Jennings to schedule an inspection of the improvements.)

25. The final plat must be submitted to Land Use Codes for review and approval for recording with the County Register of Deeds, and the plat must be recorded prior to any permit application for any structure and/or prior to the sale of any lot or unit within this development.

**Plat-Required Statements:**

26. Since this development is located within the *Farmland Protection Area* as defined on the current Land Use Plan map, the following disclosure statement shall be provided on the final plat:

"This property or neighboring property may be subject to inconvenience, discomfort, and the possibility of injury to property and health arising from normal and accepted farming and agricultural practices and operations, including but not limited to noise, odors, dust, the operation of any kind of machinery the storage and disposal of manure, and the application of fertilizers, soil amendments, herbicides, and pesticides."

27. The final plat shall reflect the following statements required for the private street(s):

"No public agency is presently responsible for maintenance of the private street(s) shown on this plat. Private streets are for the use of all owners of property within this development and their guests; and any governmental agency or personnel or equipment thereof who shall be granted perpetual access over all such private streets to accomplish or fulfill any service or function for which the agency is responsible and that any agency or organization designated by a governmental agency to perform a designated function shall also retain access the same as any government agency. Any governmental agency exercising its access rights shall have the same rights and only such liabilities as it would have on any public lands, rights-of-way, or easements."

28. If it is determined that public water and/or sewer is not available and private well(s) and/or septic tank(s) are used to serve this development, the following statement must be reflected on the final plat:

"The individual lots in this development do not have public sewer and/or water services available, and no lots have been approved by the Health Department for on-site sewer services or been deemed acceptable for private wells at the date of this recording."

29. The all structures shall be shown on the final plat or the final plat shall reflect the following statement:

"Nonconforming structures have not been created by this subdivision."

**Other Relevant Conditions:**

30. The owner/developer be aware that every deed created for the purpose of conveying a lot served by a private street must contain the following disclosure statement at the time of recordation with the County Register of Deeds:

"It is hereby acknowledged that a subdivision streets disclosure statement has been executed in accordance with N.C.G.S 136-102.6(f)."

31. The owner/developer be aware that every deed created for a lot being served by an on-site water and/or sewer system must contain the following disclosure when filed with the County Register of Deeds:

"Public water and/or sewer services are not available as of the date of the recording of this deed. On-site sewer disposal systems must be approved by the County Health Department."

MINUTES OF MARCH 20, 2007

Mr. Lloyd presented the case information and stated that staff had reviewed this case on January 8, 2007 and recommended denial of the R15/Density Development/Conditional Use District and Permit. Rather than present this recommendation to the Board and in order to give the applicant an opportunity to correct what the Staff found to be deficiencies in the application and the site plan, the Staff requested a deferral for this case at the January 16, 2007 Board meeting. The applicant subsequently revised the application and the site plan with the request remaining R15/DD/CUD&P. Staff met again on this request, reviewing the revised application and site plan, and recommends denial of the R15/Density Development/Conditional Use District based on the findings that: the district requested is inconsistent with the 2010 Land Use Plan which calls for "farmland" at this location; the request, qualifying as unreasonable, is not in character with the lot sizes of the surrounding properties and would not be in harmony with the surrounding land uses since the subject property is located within an area that consists primarily of A1 Agricultural zoning with relatively small areas of RR Rural Residential and R40 Residential zoning districts; and favorable consideration of this request for this area is arbitrary and would not serve a viable public interest when the current state of the right-of-way is taken into consideration. Old Vander Road is a "minor thoroughfare", in which severe congestion exists, qualifying this request as unreasonable. In addition to the existing school traffic, a 230 lot subdivision with direct access to Old Vander Road was approved as a "use by right" in March 2006. Staff also recommends denial of the Conditional Use Permit based on the findings that the proposed development of 102 lots at this location is not in the public interest because of the state of Old Vander Road as previously noted; the extension of utilities being highly improbable at this location since the closest public water and sewer lines available for extension are North of the railroad tracks serving the previously mentioned development of 230 lots are north of the railroad track; there is a substantial portion of hydric soils on the subject property; and the degree of difference in the surrounding land uses and lot sizes compared to the proposed lots shown on the site plan is such that this request qualifies as being unreasonable. A possible suitable zoning district that could be considered for this request would be a R40/Density Development/Conditional Use District and Permit.

MINUTES OF APRIL 17, 2007:

The Staff recommended approval of the R40/Density Development/Conditional Use District based on the following:

1. The request is reasonable and consistent with the existing lot sizes, zoning and land uses within the general area; and
2. The request is consistent with the 2010 Land Use Plan which calls for "farmland" at this location. Note: The 2010 LUP finds the R40 zoning district to be suitable in areas designated for "farmland".

The Staff recommended approval of the Conditional Use Permit based on:

1. The use will not materially endanger the public health or safety if located according to the plan submitted and recommended – the site plan as submitted meets or exceeds the minimum development standards for subdivisions within the County, as well as complying with the criteria established in Article VIII of the County Ordinance, the adopted minimum submission criteria for approval of a Density Development.
2. The use meets all required conditions and specifications – the owner's written confirmation of her agreement with the Ordinance Related Conditions is attached;

3. The use will maintain or enhance the value of adjoining or abutting properties – the developer is aggressively pursuing the extension of public water and sewer to the site, working in conjunction with the Public Works Commission and the applicant is proposing a quality development that should aid in the enhancement of the property values within the area;
4. The location and character of the use, if developed according to the plan as submitted and recommended, will be in harmony with the area in which it is to be located and in general conformity with Cumberland County's most recent Land Use Plan and adopted planning policies – as stated above, the request is consistent with the Land Use Plan and is also within keeping of the character of the general area.

**A motion was made by Mrs. Piland and seconded by Vice-Chair McLaurin to follow the staff recommendations and approve R40/Density Development/Conditional Use District because the application is reasonable, neither arbitrary nor unduly discriminatory and in the public interest. The motion passed unanimously.**

**A motion was made by Mrs. Piland and seconded by Vice-Chair McLaurin to approve the Conditional Use Permit after finding that when completed, the proposal: 1) will not materially endanger the public health and safety; 2) will not substantially injure the value of adjoining or abutting property; 3) will be in harmony with the area in which it is to be located; and 4) will be conformity with the land use plan, thoroughfare plan or other plan officially adopted by the Board of Commissioners. The motion passed unanimously.**

TO THE CUMBERLAND COUNTY JOINT PLANNING BOARD AND THE BOARD OF COUNTY COMMISSIONERS OF CUMBERLAND COUNTY, NC:

I (we), the undersigned, hereby submit this application, and petition the County Commissioners to amend and to change the zoning map of the County of Cumberland as provided for under the provisions of the County Zoning Ordinance. In support of this petition, as hereinafter requested, the following facts are submitted:

1. APPLICANT/AGENT: Robert V. Harris
2. ADDRESS: 2311 W. 1st St. W. Harris ZIP CODE: 27533
3. TELEPHONE: (Home) (703) 932-2850 (Work) 703-548-6000 X3478
4. Location of Property: Old Powder Road (SR 2012B), 283012 Plot # 3084 pg. 599
5. Parcel Identification Number (PIN #) of subject property: # 0476-00-8189 (also known as Tax ID Number or Property Tax ID)
6. Acreage: 11.871 +/- Per Frontage: 2,600 +/- Depth: 696 +/-
7. Water Provider: Municipal
8. Sewage Provider: Municipal
9. Deed Book: 237 Page(s) 337, Cumberland County Registry. (Attach copy of deed of subject property as it appears in Registry).
10. Existing use of property: None (Agricultural zone)
11. Proposed use(s) of the property: Residential Community, consisting of (Club House) Country Club
12. It is requested that the foregoing property be rezoned FROM: Agricultural

TO: (select one)

Conditional Use District, with an underlying zoning district of R90 (Article V)

Mixed Use/Conditional Use District (Article VI)

Planned Neighborhood District/Conditional Use District (Article VII)

Density Development/Conditional Use District, at the R90 Density (Article VIII)



APPLICATION FOR  
CONDITIONAL USE PERMIT

1. PROPOSED USE(S):

A. List the use(s) proposed for the Conditional Use Permit. (Use of the underlying district will be restricted only to the use(s) specified in this application.)

*Infrastructure to build homes*

B. Density: List the amount of acreage that will be residential, commercial, and/or open space, and the number of lots and/or dwelling units proposed, and the square footage of the non-residential units.

*for a green energy solar plant & water pumping station on Club House Area*  
Residential = 47 luxury homes;  
Recreational Bldg = 5 floors; pools (2); playground, 2nd floor tennis courts, softball field; walking & bike trail; Community center gated.

2. DIMENSIONAL REQUIREMENTS:

A. Reference either the dimensional requirements of the district, Sec. 1104 or list the proposed setbacks.

*Reference B & D under section 803 pg. 54*

B. Off-street parking and loading, Sec. 1202: List the number of spaces, type of surfacing material and any other pertinent information.

*Residential & Driveways @ car*

3. SIGN REQUIREMENTS:

Reference the district sign regulations proposed from Article XIII.

*Will follow zoning guidelines  
Basic Foundation; Flat sign meeting zoning guidelines, lighted.*

4. LANDSCAPE AND BUFFER REQUIREMENTS:

A. For all new non-residential and mixed use development abutting a public street, indicate the number and type of large or small ornamental trees used in the streetscape, yard space, and/or parking areas, plus the number and type of shrubs (Sec. 1102N). NOTE: All required landscaping must be included on the site plan.

*NA*

B. Indicate the type of buffering and approximate location, width and setback from the property lines.

*FENCE  
Tree lines and shrubs  
Street lights*

5. MISCELLANEOUS:

List any information not set forth above, such as the days and hours of the operation, number of employees, exterior lighting, noise, odor and smoke, emission controls, etc.

*Monday - Friday 7am - 7:30 PM  
All other NA*

6. SITE PLAN REQUIREMENTS:

The application shall include a site plan drawn to the specifications of Sec. 1402. If the proposed uses involve development subject to the County Subdivision Ordinance, the site plan required may be general in nature, showing a generalized street pattern, if applicable, and the location of proposed uses. If the proposed uses include development not subject to the Subdivision Ordinance, the site plan shall be of sufficient detail to allow the Planning and Inspections Staff and the Planning Board to analyze the proposed uses and arrangement of uses on the site. It shall also include the footprints of all buildings (proposed and existing), the proposed number of stories, location and number of off-street parking and loading spaces, proposed points of access to existing streets and internal circulation patterns. In addition, the location of all proposed buffers and fences and landscaping shall be included on the site plan.

**REQUEST: R40/DENSITY DEVELOPMENT/CONDITIONAL USE PERMIT**

**CASE NO: P07-04 ACREAGE: 42.532+/-**

**SCALE: NTS**

**SITE PLAN CALCULATIONS**

TOTAL ACREAGE: 1,852,711 SF - 42.532 AC  
 TOTAL R/W: 140,659 SF - 3.229 AC  
 CUD APPLICABLE ACREAGE: 1,712,052 SF - 39.303 AC

60% ACREAGE - 1,111,627 SF - 25.519 AC  
 40% ACREAGE - 741,084 SF - 17.013 AC

NUMBER OF LOTS ALLOWED: 1,712,052/40,000 = 42  
 NUMBER OF LOTS PROVIDED: 42

AVERAGE SIZE PER LOT: 40,763 SF

**OPEN SPACE PROVIDED**

BUFFER - 189,703 SF - 4.355 AC  
 BIKE TRAIL - 87,689 SF - 1.554 AC  
 OPEN SPACE - 484,321 SF - 11.119 AC

TOTAL 741,713 SF - 17.027 AC (PROVIDED)  
 (741,084)SF - (17.013 AC) (REQUIRED)

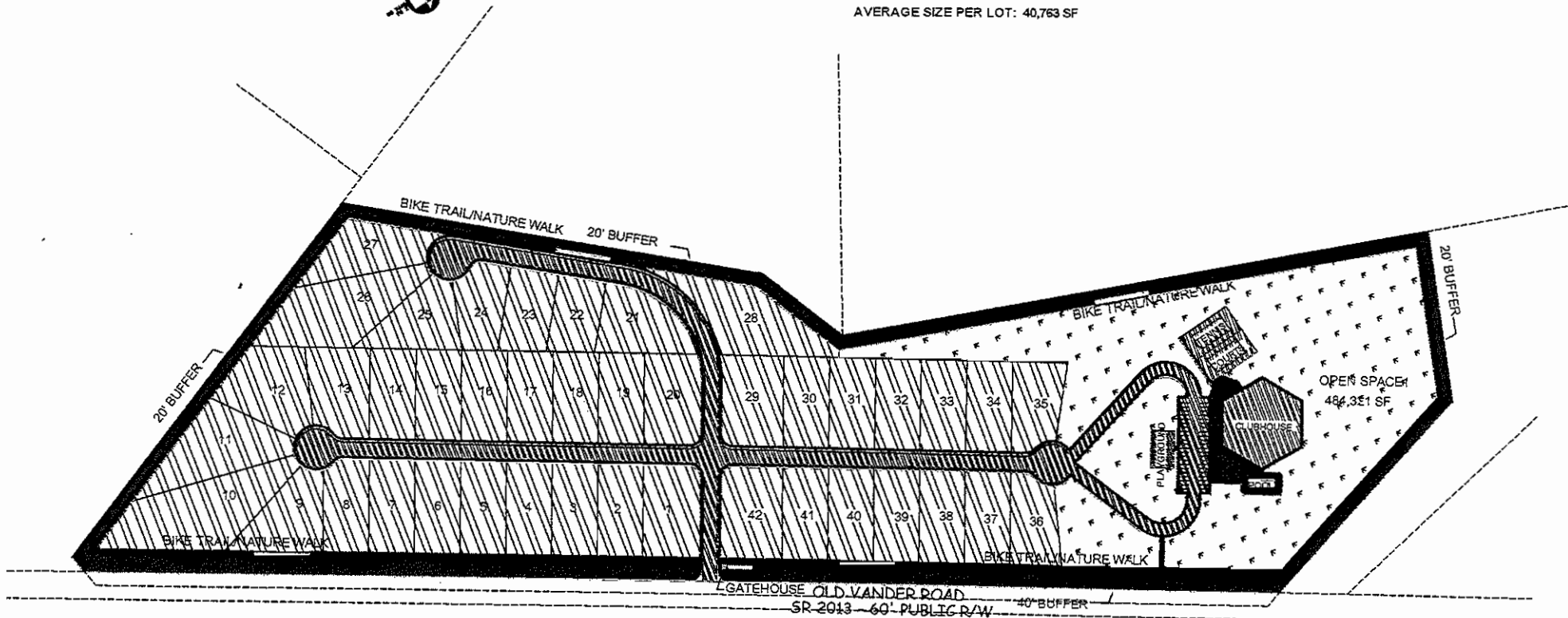

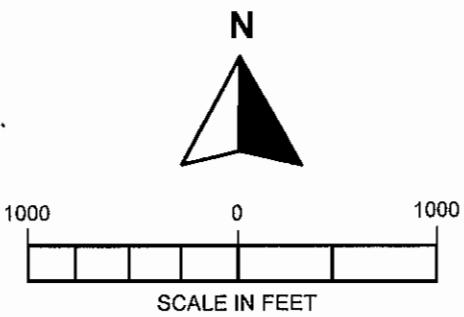
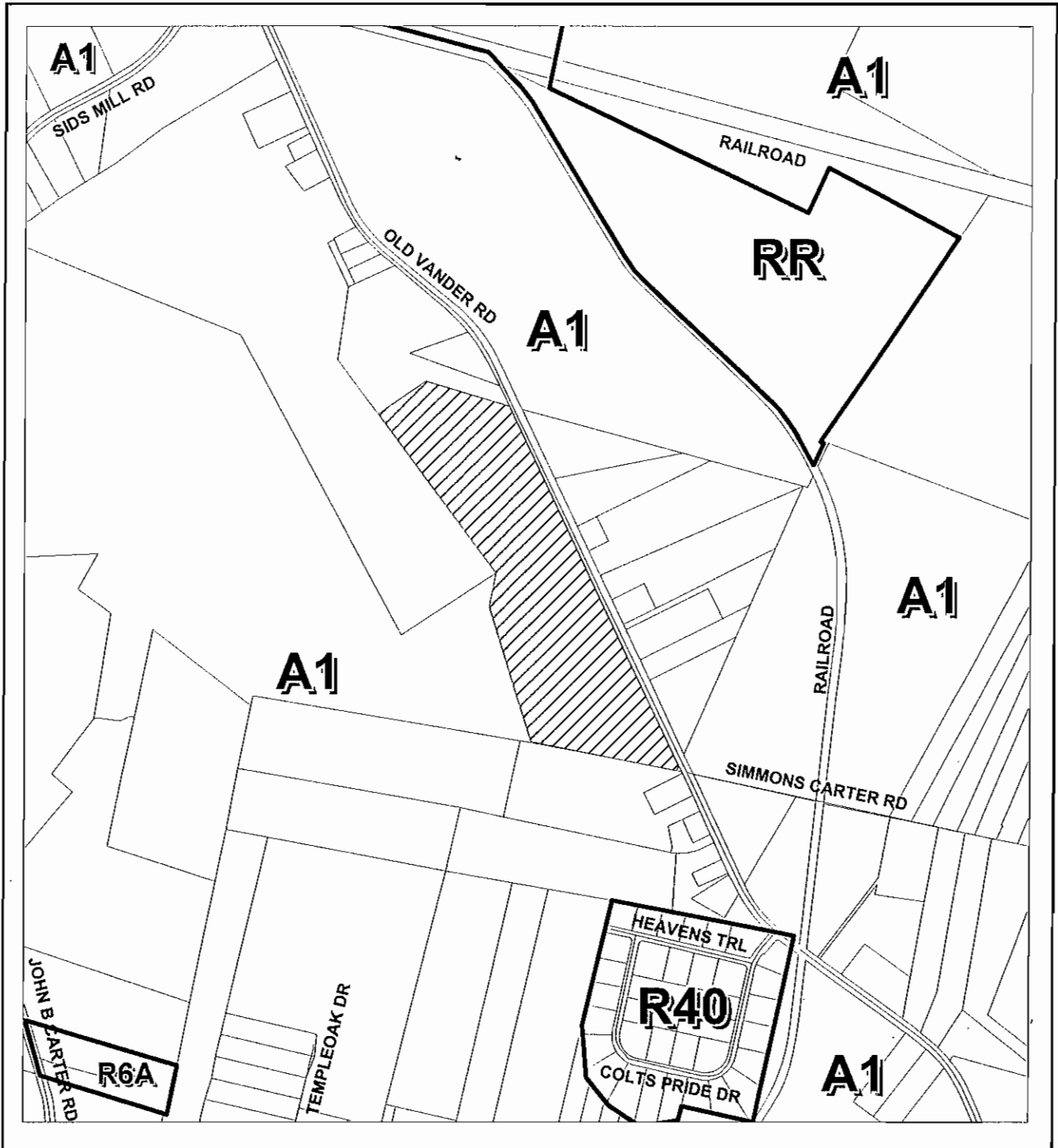

**REQUESTED REZONING:  
A1 TO R15/DD/CUD**

<b>ACREAGE: 42.532 AC.+/-</b>		<b>HEARING NO: P07-04</b>	
ORDINANCE: COUNTY	HEARING DATE	ACTION	
PLANNING BOARD			
GOVERNING BOARD			

MOTIONS ON CONDITIONAL USE OVERLAY DISTRICT REZONING  
APPLICATION

If the motion is to approve:

I move that the Board of Commissioners finds that this conditional use district overlay application is reasonable, neither arbitrary nor unduly discriminatory, and in the public interest, and that it be approved.

If the motion is to deny:

I move that the Board of Commissioners fail to find that this conditional use district overlay application is reasonable, neither arbitrary nor unduly discriminatory, and in the public interest, and that it be denied.

See Zoning Ordinance Sec. 4.23.1(b).

MOTIONS ON CONDITIONAL USE OVERLAY PERMIT APPLICATION

If the motion is to approve:

I move that the Board of Commissioners finds that this conditional use district overlay permit application, if completed as proposed,

- (i) will not materially endanger the public health and safety, and
- (ii) will not substantially injure the value of adjoining or abutting property, and
- (iii) will be in harmony with the area in which it is to be located, and
- (iv) will be in conformity with the land use plan, thoroughfare plan or other plan officially adopted by the Board of Commissioners,

and that it be approved.

If the motion is to deny:

I move that the Board of Commissioners fails to find that this conditional use district overlay permit application, if completed as proposed,

[Specify one or more of (i) through (iv) above AND state a reason for the failure to make such finding(s) based on substantial, material and competent evidence in the record on the application before the Board]

and that it be denied.

See Zoning Ordinance Sec. 4.23.2(a).

KENNETH S. EDGE  
Chairman

J. BREEDEN BLACKWELL  
Vice Chairman

JEANNETTE M. COUNCIL  
JOHN T. HENLEY, JR.  
BILLY R. KING  
EDWARD G. MELVIN  
DIANE WHEATLEY

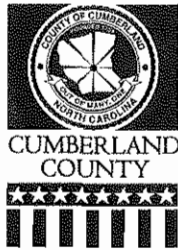

ITEM NO.

3A

MARSHA S. FOGLE  
Clerk to the Board

MARIE COLGAN  
Deputy Clerk

**BOARD OF COMMISSIONERS**

5th Floor, New Courthouse • P.O. Box 1829 • Fayetteville, North Carolina 28302-1829  
(910) 678-7771 • Fax: (910) 678-7770

May 8, 2007

**May 21, 2007 Agenda Item**

**MEMORANDUM**

TO: Board of Commissioners

FROM: Marie Colgan, Deputy Clerk *MC*

SUBJECT: ABC Board Vacancies (2)

The following two (2) positions on the ABC Board will become vacant on June 30, 2007:

**Glenn B. Adams** - Completing first term. Eligible for reappointment.

Stanley Johnson - Completing second term. Not eligible for reappointment.

I have attached the current membership and applicant list for this board.

**PROPOSED ACTION:** Make nominations to fill the vacancies (2).

Attachments

pc: Gene Webb, ABC Board General Manager

*Celebrating Our Past...Embracing Our Future*

## ABC BOARD

## 3 Year Term

<u>Name/Address</u>	<u>Date Appointed</u>	<u>Term</u>	<u>Expires</u>	<u>Eligible For Reappointment</u>
Stephen T. Horne, Jr. (W/M) 801 Fairfield Road Fayetteville, NC 28303 484-0487 (filling unexpired term)	12/06	1st	June/08 6/30/08	Yes
Edward Maynor (AI/M) 3718 Floyd Drive Hope Mills, NC 28348 424-4214/425-5668(W)	6/06	1st	June/09 6/30/09	Yes
Stanley Johnson (W/M) 4718 Cameron Road Hope Mills, NC 28348 425-4509	5/04	2nd	June/07 6/30/07	No
Glenn B. Adams 407 Hilliard Drive Fayetteville, NC 28311 822-4578/678-8900(W)	5/04	1st	June/07 6/30/07	Yes
Valerie Wynne-Hall ( /F) 327 E. Lock Haven Drive Fayetteville, NC 28314 868-6755/424-7665(W) (filling unexpired term)	12/06	1st	June/08 6/30/08	Yes

Commissioner Liaison: Kenneth Edge

Regular Meetings: 2nd Monday of the month at 6:00 PM in the Conference Room at the office on Owen Drive (1705 Owen Drive, Fayetteville, NC 28304).

Contact: ABC Board General Manager Gene Webb, 484-8167.

APPLICANTS FOR  
ABC BOARD

<u>NAME/ADDRESS/TELEPHONE</u>	<u>OCCUPATION</u>	<u>EDUCATIONAL BACKGROUND</u>
ALLEN, CINDY (W/F) 2233 WILMINGTON HIGHWAY FAYETTEVILLE, NC 28306 483-3213/323-8811(W) <b>**SERVES ON THE JOINT APPEARANCE COMMISSION**</b>	OWNER -NURSERY & LANDSCAPING COMPANY	ASSOCIATE DEGREE: DENTAL ASSISTANT
BLANCO, SWANY (B/ ) 6512 WINDY CREEK WAY FAYETTEVILLE, NC 28306 864-3674/323-2875(W)	COUNSELOR	MA – COUNSELING
CHAVIS, DR. ANNIE M. (B/F) 3454 THORNDIKE DRIVE FAYETTEVILLE, NC 28311 488-9555/672-1852(W)	COLLEGE PROFESSOR	
CHAVIS, LANDIS REED (W/M) 3855 CEDAR CREEK ROAD FAYETTEVILLE, NC 28312 483-1729/483-4783(W)	OWNER/PRESIDENT PLUMBING CO.	HIGH SCHOOL
CHESTNUTT, A. JOHNSON(W/M) 578 MILDEN ROAD FAYETTEVILLE, NC 28314 484-6365/323-1040(W)	ACCOUNTANT	BSBA
CHISOLM, ALICIA S. (AA/F) 1855 CASCADE STREET FAYETTEVILLE, NC 28301 488-7820/488-5935 (W) <b>**SERVES ON THE CIVIC CENTER COMMISSION**</b>	SELF EMPLOYED RETIRED DOA CIVILIAN	MBA & BS – BUSINESS ADMIN/MGT
FADDIS, JAMES M. (W/M) 1871 WINDLOCK DRIVE FAYETTEVILLE, NC 28304 425-5739/396-6511 (W)	INFO TECH SUPERV. RETIRED ARMY	AS – ELECTRONICS TECH AA – GENERAL EDUCATION
FLEMING, JOE (B/M) 7235 RYAN STREET FAYETTEVILLE, NC 28314 868-1428/257-7323 <b>**SERVES ON THE NURSING HOME ADVISORY BOARD**</b>	RETIRED	16 YEARS
GOULD, DENNIS G. (W/M) 709 CALAMAR DR FAYETTEVILLE, NC 28314 860-2563/818-6384 (C) <b>**SERVES ON THE STORM WATER ADVISORY BOARD**</b>	RETIRED	3 YRS COLLEGE
HALL, R. KEITH (C/M) 5744 MACK SIMMONS FAYETTEVILLE, NC 28312-7776 485-6836	USN RETIRED	HS/USN SCHOOLS
HASTY, ROBERT A. (W/M) 503 FOREST ROAD FAYETTEVILLE, NC 28305 484-4400	RETIRED/BANKER	2 YEARS COLLEGE (BUS ADM)



ABC BOARD APPLICANTS, PAGE 2

EDUCATIONAL

<u>NAME/ADDRESS/TELEPHONE</u>	<u>OCCUPATION</u>	<u>BACKGROUND</u>
HUMPHREY, HORACE (B/M) 1852 CASCADE STREET FAYETTEVILLE, NC 28301 488-5143/850-5170 (CELL)	RETIRED	BACHELOR OF SCIENCE
INGRAM, JAMES (B/M) PO BOX 87671 FAYETTEVILLE, NC 28304 257-1831/488-8415(W)	EDUCATION ADMIN.	BA, MA, ED.S
JOHNSON, LENNIE E. (W/M) 6360 SMITHFIELD WADE, NC 28395 980-1401	RETIRED – LAW ENFORCEMENT	SOME COLLEGE L.E. ACADEMY
KEEFE, JIMMY (W/M) 370 ECHO LANE FAYETTEVILLE, NC 860-7706/323-1791, EXT. 303 (W)	OWNER/OPERATOR TROPHY HOUSE	CITADEL GRADUATE
KNIGHT, BOBBY L. (W/M) PO BOX 1842 FAYETTEVILLE, NC 28302 323-0023/624-5533(W)	SEMI-RETIRED REAL ESTATE INVESTMENTS	HIGH SCHOOL
LEACH, JACQUELINE (AA/F) 5520 MARCIA STREET FAYETTEVILLE, NC 28303 868-4897/677-2977(W)	VISTA VOLUNTEER AMERICORP	ACCOUNTING DEGREE
LEWIS, SHERYL J. (W/F) 3011 BANKHEAD DRIVE FAYETTEVILLE, NC 28306 426-6999	RETIRED EDUCATOR	BA, MA, ED.S.
MACK, DAVID JAMES (B/M) 5479 LYNBROOK COURT FAYETTEVILLE, NC 28314 867-1214 <b>**SERVES ON THE EQUALIZATION &amp; REVIEW BOARD**</b>	RETIRED SCHOOL ADMINISTRATOR	
MANNING, BILLY H. (B/M) 718 RUSTLAND DRIVE FAYETTEVILLE, NC 28301 822-1919/483-7111	RETIRED MILITARY & CC SHERIFF'S DEPT	ASSOC. POLICE SCIENCE & BUSINESS LAW
MATTHEWS, GEORGE E. (B/M) 6984 KINGS LYNN LOOP FAYETTEVILLE, NC 28304 487-3904/396-8169/2227	GOVT. CONTRACT EMPLOYEE	BS – TECH. AERONAUTICS MA – HUMAN RELATIONS
MCFADYEN, WILLIAM DAVID (W/M) 7122HUNTERS POINT DRIVE FAYETTEVILLE, NC 28311 822-2362	RETIRED PART-TIME COURIER	ASSOC. DEGREE – BUSINESS ADMIN.

ABC BOARD APPLICANTS, PAGE 3

<u>NAME/ADDRESS/TELEPHONE</u>	<u>OCCUPATION</u>	<u>EDUCATIONAL BACKGROUND</u>
MERCER, CARLON G. (W/M) 1846 WAYNE LANE FAYETTEVILLE, NC 28304 425-0243/624-4334 (C)	RETIRED	HS, CONTINUING EDUC COURSES
MURRAY, JEFFREY W. (W/M) 4743 DENTON COURT FAYETTEVILLE, NC 28306 425-7046/977-6180 (W)	CONSULTANT	MS/BS/AA
POOLE, ROBERT E. (W/M) 2700 BRIARCREEK PLACE FAYETTEVILLE, NC 28304 678-8197/483-1367 (W)	PRESIDENT/MANAGER POOLE OFFICE INTERIORS	HS/40 YRS OF BUSINESS MANAGEMENT
POPE, RITA J. (B/F) 679 BARTON'S LAND PL #4 FAYETTEVILLE, NC 28314 864-4993	RETIRED JAILER	SOME COLLEGE
SALLEY, LUKE (B/M) 104 UNIVERSITY AVENUE FAYETTEVILLE, NC 28301 364-8505/483-0121 (W)	RETIRED CORRECTIONAL CAPTAIN	BA – ECONOMICS & ACCOUNTING
SHORTER, FLOYD L. (AA/M) 6438 TOUCHSTONE DRIVE FAYETTEVILLE, NC 28311 822-6403/222-8915 (W) <b>**SERVES ON THE CIVIC CENTER COMMISSION**</b>	COLLEGE ADMINISTRATOR	BS – SCIENCE/ BUS MGT
SUTTON, CARRIE (F) 5422 SUMMER DUCK ROAD FAYETTEVILLE, NC 28314 864-5567/483-7695 (W)	REP – BUSINESS	COLLEGE DEGREE (UNKNOWN)
WATSON LORA (W/F) 3509 GOLFVIEW DRIVE HOPE MILLS, NC 28348 485-3558/678-0700 (W)	PROJECT COORDINATOR OFFICE MANAGER	AS –BUSINESS ADMIN OPERATIONS MGT
WILLIFORD, CARL P. (PAT)(W/M) 951 S. MCPHERSON CHURCH ROAD FAYETTEVILLE, NC 28303 223-0223/484-2168(W)	CPA	BS/BA
YEPEZ, JOSE ( /M) 3900 FOSTER DRIVE FAYETTEVILLE, NC 28311 488-4423/728-8660	RETIRED	BS-BUSINESS AS-PUBLIC ADMIN

KENNETH S. EDGE  
Chairman



MARSHA S. FOGLE  
Clerk to the Board

J. BREEDEN BLACKWELL  
Vice Chairman

MARIE COLGAN  
Deputy Clerk

JEANNETTE M. COUNCIL  
JOHN T. HENLEY, JR.  
BILLY R. KING  
EDWARD G. MELVIN  
DIANE WHEATLEY

**BOARD OF COMMISSIONERS**

5th Floor, New Courthouse • P.O. Box 1829 • Fayetteville, North Carolina 28302-1829  
(910) 678-7771 • Fax: (910) 678-7770

May 8, 2007

**May 21, 2007 Agenda Item**

TO: Board of Commissioners  
FROM: Marie Colgan, Deputy Clerk *mc*  
SUBJECT: Animal Control Board Vacancies (3)

The Animal Control Board will have the following vacancies on June 30, 2007:

Ex-Officio The Veterinarian on Contract to the Animal Control Department Position  
**Dr. John Lauby** – Completing third term. Eligible for reappointment.

At-Large Positions

**Edwin A. Hamblin** – Completing first term. Eligible for reappointment.  
**Wallace Owens** – Completing first term. Eligible for reappointment.

I have attached the current membership list and applicant list for this board.

**PROPOSED ACTION:** Make nomination to fill the vacancies (3).

cc: Sue Nicholson, Animal Control Director

ANIMAL CONTROL BOARD  
3 Year Term  
(Terms extended from 2 to 3 years on 8/5/02.)

<u>Name/Address</u>	<u>Date Appointed</u>	<u>Term</u>	<u>Expires</u>	<u>Eligible For Reappointment</u>
<u>Knowledge &amp; Experience in Dog Behavior and/or Handling Position</u>				
Paula Thomason 1660 River Road Fayetteville, North Carolina 28312 483-9213	5/06	2nd	June/09 6/30/09	No
<u>Promoting Goals of the Animal Protection Society or the Humane Society or Another Such Broadly-Based and Representative Organization Interested in the Care and Protection of Animals Position</u>				
Tommy Griffin 530 Lennox Drive Fayetteville, North Carolina 28303	5/06	2nd	May/09 5/31/09	No
<u>Ex-Officio, The Veterinarian on Contract to the Animal Control Department Position</u>				
Dr. John Lauby (W/M) East Fayetteville Veterinary Clinic 118 Cedar Creek Road Fayetteville, North Carolina 28301 323-5845	6/04	3 <sup>rd</sup>	June/07 6/30/07	
<u>At-Large Positions</u>				
Edwin A. Hamblin (W/M) 6653 Rockfish Road Fayetteville, North Carolina 28306 425-0170	6/04	1 <sup>st</sup> full	June/07 6/30/07	Yes
Wallace Owens 1888 Cascade Street Fayetteville, North Carolina 28301 488-9064	6/04	1 <sup>st</sup>	June/07 6/30/07	Yes
<u>City of Fayetteville Resident Positions</u>				
Carol Langdon P.O. Box 35541 Fayetteville, North Carolina 28303 868-4038	6/05	2nd	June/08 6/30/08	No
Linda Hardy Lewis 411 Lakeshore Drive Fayetteville, North Carolina 28305 485-4960	5/06	2nd	June/09 6/30/09	No

Board was Established by Ordinance adopted on January 4, 1999.

Meetings: Bi monthly – 1<sup>st</sup> Monday, 6:00PM (Courthouse) - Contact: Sue Nicholson 321-6851

APPLICANTS FOR  
ANIMAL CONTROL BOARD

<u>NAME/ADDRESS/TELEPHONE</u>	<u>OCCUPATION</u>	<u>EDUCATIONAL BACKGROUND</u>
FLEMING, JOE (B/M) 7235 RYAN STREET FAYETTEVILLE, NC 28314 868-1428/257-7323 <b>**SERVES ON THE NURSING HOME ADVISORY BOARD**</b>	RETIRED	16 YEARS
HURLEY, MICHELE (W/F) 4216 BARTLET GLEN LANE FAYETTEVILLE, NC 28306 425-2793/904-7407 (W)	PHYSICAL THERAPIST	BS – SPORTS MED BS – PHY THERAP
LUDDINGTON, KIMBERLY, DVM 5429 KENTUCKY LANE HOPE MILLS, NC 28348 425-0720	VETERINARIAN	DOCTOR OF VETERINARY MED.
WILLIAMS, ENNIS V. (B/M) 2036 WHEELING STREET FAYETTEVILLE, NC 28303 867-2248/578-1877 (W)	VETERNARIAN	BS – MICROBIO DOCTOR OF VET MEDICINE

ITEM NO. 30

MARSHA S. FOGLE  
Clerk to the Board

MARIE COLGAN  
Deputy Clerk

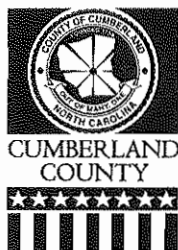

**BOARD OF COMMISSIONERS**

5th Floor, New Courthouse • P.O. Box 1829 • Fayetteville, North Carolina 28302-1829  
(910) 678-7771 • Fax: (910) 678-7770

KENNETH S. EDGE  
Chairman

J. BREEDEN BLACKWELL  
Vice Chairman

JEANNETTE M. COUNCIL  
JOHN T. HENLEY, JR.  
BILLY R. KING  
EDWARD G. MELVIN  
DIANE WHEATLEY

May 8, 2007

**May 21, 2007 Agenda Item**

TO: Board of Commissioners  
FROM: Marie Colgan, Deputy Clerk *MC*  
SUBJECT: Board of Adjustment Vacancies (2)

The Board of Adjustment will have the following vacancies on June 30, 2007:

**Oscar L. Davis, III** – Completing first term. Eligible for reappointment

Alternate Members

**Johnnie Lee Council** – Completing first term. Eligible for reappointment.

I have attached the current membership list and applicant list for this Board.

**PROPOSED ACTION:** Make nomination to fill the vacancies (2).

cc: Tom Lloyd, Planning/Inspections Director

*Celebrating Our Past... Embracing Our Future*

BOARD OF ADJUSTMENT  
3 Year Term

<u>Name/Address</u>	<u>Date Appointed</u>	<u>Term</u>	<u>Expires</u>	<u>Eligible For Reappointment</u>
Joe Potts(C/M) 1200 Goodview Avenue Fayetteville, NC 28305 484-6506/818-3783(Cell)	6/06	1st full	June/09 6/30/09	Yes
Oscar L. Davis, III (C/M) 3320 Rustburg Drive Fayetteville, NC 283053 867-2950/977-3101(W)	6/04	1st	June/07 6/30/07	Yes
Sean Scott Fincher (W/M) 1822 Bondwood Street Fayetteville, NC 28301 484-9947/483-3027(W)/237-3565(Cell)	8/04	1st	Aug/07 8/31/07	Yes
Steve Parsons(W/M) 3701 Clearwater Drive Fayetteville, NC 28311 822-4155/822-2000(W)	9/06	2nd	Sept/09 9/30/09	No
George Quigley (W/M) 618 Blawell Circle Stedman, NC 28391 485-2980/321-6882	6/06	1st	June/09 6/30/09	Yes
<u>Alternate Members:</u>				
Steve Burnett (W/M) 438 Grape Arbor Drive Fayetteville, NC 28312-7205 486-9325/485-2100(W)	8/04	1st	Aug/07 8/31/07	Yes
Joseph Dykes (B/M) 5764 Pepperbush Drive Fayetteville, NC 28304 423-5255/322-0602(W)	11/05 to fill unexp. term	1st	Aug/07 8/31/07	Yes
Johnnie Lee Council(B/M) 3429 Sandystone Circle Fayetteville, NC 28311 488-0379(H)	8/05 to fill unexp. term	1 <sup>st</sup>	June/07 6/30/07	Yes

Board of Adjustment, page 2

<u>Name/Address</u>	<u>Date Appointed</u>	<u>Term</u>	<u>Expires</u>	<u>Eligible For Reappointment</u>
<u>Alternate Members Continued:</u>				
Melree Hubbard Tart(W/F) 300 Andrews Road Fayetteville, NC 28311 488-1208/497-3712(W)	1/04	2 <sup>nd</sup>	Jan/10 1/31/10	No
Martin J. Locklear (I/M) 1611 Four Wood Drive Fayetteville, NC 28312 672-0323/893-7525(W)	8/06	1 <sup>st</sup>	Aug/09 8/31/09	Yes

Meets 3<sup>rd</sup> Thursday of each month at 7:00 PM – Historic Courthouse, Room 3



APPLICANTS FOR  
BOARD OF ADJUSTMENT

<u>NAME/ADDRESS/TELEPHONE</u>	<u>OCCUPATION</u>	<u>EDUCATIONAL BACKGROUND</u>
CHESTNUTT, A. JOHNSON(W/M) 578 MILDEN ROAD FAYETTEVILLE, NC 28314 484-6365/323-1040(W)	ACCOUNTANT	BSBA
FRANKLIN, BETTY (W/F) 6499 PERICAT DRIVE FAYETTEVILLE, NC 28306 425-0008/323-3418(W)	OFFICE ADMINISTRATOR	HS, SALES & NEGOTIATING COURSES
INGRAM, JAMES (B/M) PO BOX 87671 FAYETTEVILLE, NC 28304 257-1831/488-8415(W) <b>**SERVES ON THE ADULT CARE HOME COMMUNITY ADVISORY COUNCIL**</b>	ASST. PRINCIPAL	POST GRADUATE
JOHNSON, JASON N. (B/M) 8436 UMSTEAD ROAD FAYETTEVILLE, NC 28304 864-3999	UNEMPLOYED	BA – POLITICAL SCIENCE (RECENT COLLEGE GRAD)
LEACH, JACQUELINE (AA/F) 5520 MARCIA STREET FAYETTEVILLE, NC 28303 868-4897/677-2977(W)	VISTA VOLUNTEER AMERICORP	ACCOUNTING DEGREE
SWANSON, JOHN R. (W/M) 6416 COACHMAN'S WAY FAYETTEVILLE, NC 28303 987-1972/822-2000(W)	CERTIFIED RESIDENTIAL APPRAISER/BROKER	BA – CRIM. JUSTICE MPA – PUBLIC ADMIN.
WINSTEAD, SUSAN (C/F) 3204 BROADVIEW DRIVE FAYETTEVILLE, NC 28301 306-0148/630-1587(W)	BUSINESS CONSULTANT TECHNOLOGY MANAGER	BA – POLITICAL SCIENCE MS – BUSINESS ADMIN.

KENNETH S. EDGE  
Chairman

J. BREEDEN BLACKWELL  
Vice Chairman

JEANNETTE M. COUNCIL  
JOHN T. HENLEY, JR.  
BILLY R. KING  
EDWARD G. MELVIN  
DIANE WHEATLEY

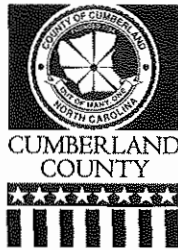

MARSHA S. FOGLE  
Clerk to the Board

MARIE COLGAN  
Deputy Clerk

**BOARD OF COMMISSIONERS**

5th Floor, New Courthouse • P.O. Box 1829 • Fayetteville, North Carolina 28302-1829  
(910) 678-7771 • Fax: (910) 678-7770

May 3, 2007

**May 21, 2007 Agenda Item**

TO: Board of Commissioners  
FROM: Marie Colgan, Deputy Clerk *mc*  
SUBJECT: Board of Health Vacancy (1)

The Board of Health has the following vacancy:

Physician:

Dr. Christopher Barnes – Dr. Barnes resigned effective February 21, 2007. The Board of Health recommends **Dr. Cynthia Norris** to fill the vacancy.

I have attached the current membership list and applicant list for this Board.

**PROPOSED ACTION:** Make nomination to fill the vacancy (1).

Attachments

cc: Wayne Raynor, Health Director

BOARD OF HEALTH  
3 Year Term

<u>Name/Address</u>	<u>Date Appointed</u>	<u>Term</u>	<u>Expires</u>	<u>Eligible For Reappointment</u>
<u>Veterinarian</u>				
Dr. Ennis V. Williams (B/M) 4617 Bent Grass Drive Fayetteville, NC 28312 867-2248/578-1877(W)	01/07	1 <sup>st</sup>	Dec/09 12/31/09	No
			(already served a term as a General Public Rep)	
<u>Physician</u>				
Dr. Christopher Barnes(W/M) 3308 Melrose Road Fayetteville, NC 28304 867-6284/484-3114(W)	12/05	1 <sup>st</sup> full	Dec/08 12/31/08	Yes
<u>Dentist</u>				
Dr. Walter S. Scott, III (B/M) 686 Stockbridge Court Fayetteville, NC 28311 811-3543/323-3133(W)	01/07	1 <sup>st</sup>	Dec/09 12/31/09	Yes
<u>Registered Nurse</u>				
Kim S. McDonald (W/F) VA Medical Center 2300 Ramsey Street Fayetteville, NC 28311 482-5183/488-5989(W)	01/07	1 <sup>st</sup>	Dec/09 12/31/09	Yes
<u>Optometrist</u>				
Dr. William C. Philbrick(W/M) 321 Springbrooke Place Fayetteville, NC 28305 485-4580/484-6178(W)	12/04	2 <sup>nd</sup>	Dec/07 12/31/07	No
<u>Pharmacist</u>				
Catherine S. Roach (W/F) 3890 Cedar Creek Road Fayetteville, NC 28312 437-5149/609-1172(W)	12/05	1 <sup>st</sup>	Dec/08 12/31/08	Yes
<u>Engineer</u>				
Jeff Reitzel (W/M) 331 E. Loch Haven Fayetteville, NC 28314 864-1218/484-5191(W)	12/04	2 <sup>nd</sup>	Dec/07 12/31/07	No

<u>Name/Address</u>	<u>Date Appointed</u>	<u>Term</u>	<u>Expires</u>	<u>Eligible For Reappointment</u>
<u>General Public Reps.</u>				
Cureton L. Johnson (AA/M) 1909 Bellemeade Road Fayetteville, NC 28303 485-3025/483-6505(W)	12/05	1st	Dec/08 12/31/08	Yes
Barbara S. Marshall (B/F) 7640 Wilkins Drive Fayetteville, NC 28311 488-2615/977-2303 (W)	01/07	1 <sup>st</sup>	Dec/09 12/31/09	Yes
Carol E. Schaeffer (W/F) 1704 Cherokee Drive Fayetteville, NC 28303 223-3030/483-1437 (W)	01/07	1 <sup>st</sup>	Dec/09 12/31/09	Yes

COMMISSIONER LIAISON: John Henley

Contact: Wayne Raynor, Health Director  
Tracy Gurganus, Secretary  
Phone: 433-3720  
Fax: 433-3659

Meetings: 3rd Tuesday of the month 6:00 PM, Board Room, Health Department

APPLICANTS FOR  
BOARD OF HEALTH

<u>NAME/ADDRESS/TELEPHONE</u>	<u>OCCUPATION</u>	<u>EDUCATIONAL BACKGROUND</u>
BERRY-CABAN, CRISTOBAL S. (H/M) 5739-01 IVANHOE COURT FAYETTEVILLE, NC 28314 (813) 751-3004/907-8844	MEDICAL STATISTICIAN	PhD – URBAN SOCIAL INST. MA – HISTORY & POLITICAL SCIENCE; BA – HISTORY
HARRIS, GLENDA PURDIE(B/F) 1874 GOLA DRIVE FAYETTEVILLE, NC 28301 488-2434/630-3041(W)	COMPLIANCE OFFICER	MASTERS:ADMINISTRATION BACHELOR OF SCIENCE
JENSEN, LEESA (W/F) 719 ASHFIELD DRIVE FAYETTEVILLE, NC 28311 630-0253/433-1695(W)	HUMAN RELATIONS SPECIALIST	MASTERS: BUSINESS ADMINISTRATION
JOHNSON, LONNIE EDWARD (AA/M) 5206 LANDMARK DRIVE FAYETTEVILLE, NC 28311 488-8372/224-4841 (C) <b>**SERVES ON THE ADULT CARE HOME COMMUNITY ADV. BOARD**</b>	TRUCK DRIVER	HIGH SCHOOL GRADUATE
NORRIS, CYNTHIA M., MD (W/F) 6525 WINDY CREEK WAY FAYETTEVILLE, NC 28306 429-3258/323-9111 (W)	FAMILY PHYSICIAN	BS, MD
PAQUETTE, OMER E., DDS (C/M) 506 HILLIARD DRIVE FAYETTEVILLE, NC 28311-2677 822-2512	RETIRED ARMY DENTAL OFFICER	DDS – DIPLOMATE AMERICAN BOARD OF GEN. DENTISTRY
ROBERTSON, FREDDIE A. (B/M) ROSEHILL RD FAYETTEVILLE, NC 28301 630-6472/988-9781 (W)	COMPUTER INSTRUCTOR	BS – COMPUTER 2335 SCIENCE
SPAIN, PHYLLIS M. (B/F) PO BOX 821 SPRING LAKE, NC 28390 484-4726/916-4974(W) <b>**SERVES ON THE MENTAL HEALTH BOARD**</b>	MINISTER/CHAPLAIN	DOCTORATE OF MINISTRY CLINICAL PASTORAL ED.



KENNETH S. EDGE  
Chairman

J. BREEDEN BLACKWELL  
Vice Chairman

JEANNETTE M. COUNCIL  
JOHN T. HENLEY, JR.  
BILLY R. KING  
EDWARD G. MELVIN  
DIANE WHEATLEY

MARSHA S. FOGLE  
Clerk to the Board

MARIE COLGAN  
Deputy Clerk

**BOARD OF COMMISSIONERS**

5th Floor, New Courthouse • P.O. Box 1829 • Fayetteville, North Carolina 28302-1829  
(910) 678-7771 • Fax: (910) 678-7770

May 8, 2007

**May 21, 2007 Agenda Item**

TO: Board of Commissioners  
FROM: Marie Colgan, Deputy Clerk *MC*  
SUBJECT: Criminal Justice Partnership Advisory Board Vacancies (8)

The Criminal Justice Partnership Advisory Board will have the following vacancies on June 30, 2007:

District Attorney

**Ed Grannis** – Completing fourth term. Eligible for reappointment.

At-Large

**Kimbrell Tucker** – Completing first term. Eligible for reappointment.

**Frederick H. Frimet** – Completing first term. Eligible for reappointment.

Richard A. Hayes – Completing third term. Not eligible for reappointment.

Ralph Spivey – Completing second term. Not eligible for reappointment.

Public Defender

**Ron McSwain** – Completing fourth term. Eligible for reappointment.

County Commissioner

Billy King – Completing fourth term. Due to time constraints, Commissioner King is unable to continue to serve.

Criminal Defense Attorney

**Sherry Miller** – Completing first term. Eligible for reappointment.

I have attached the current membership and applicant lists for this board.

**PROPOSED ACTION: Make nominations to fill the vacancies (8).**

Attachments

cc: Elizabeth Keever, Chief District Court Judge  
Callie Gardner, Day Reporting Center Director

*Celebrating Our Past... Embracing Our Future*

CRIMINAL JUSTICE PARTNERSHIP ADVISORY BOARD

Established by the Board of County Commissioners May 16, 1994  
 Terms were initially set and staggered June, 1996.

<u>Name/Address</u>	<u>Date Appointed</u>	<u>Term</u>	<u>Expires</u>	<u>Eligible For Reappointment</u>
<u>Probation Officer/Assistant JDM</u>				
Jonette Quenum(/F) Div. of Community Corrections 412-A Russell Street Fayetteville, NC 28301 486-1890 (W)	8/05	1st	June/08 6/30/08	Yes
A. Wayne Marshburn, JDM Div. of Community Correction 412-A W. Russell Street Fayetteville, NC 28301 486-1161(W)	8/05	3rd	June/08 6/30/08	Yes
<u>Superior Court Judge</u> Vacant as of 4-30-07				
<u>District Court Judge</u>				
Beth Keever (W/F) Cumberland County Courthouse 117 Dick Street Fay., NC 28301 678-2901(W)	6/06	5th	June/09 6/30/09	Yes
<u>Police Chief or Designee</u>				
Lieutenant Michael Calfee Fayetteville Police Department 467 Hay Street Fay., NC 28301 433-1861	9/04	1st	Sept/07 9/30/07	Yes
<u>Sheriff or Designee</u>				
Major John McRainey Cumberland County Sheriff's Office Law Enforcement Center 131 Dick Street. Fay., NC 28301 323-1500(W)	8/05	3rd	June/08 6/30/08	Yes

CRIMINAL JUSTICE PARTNERSHIP ADVISORY BOARD PG. 2

<u>Name/Address</u>	<u>Date Appointed</u>	<u>Term</u>	<u>Expires</u>	<u>Eligible For Reappointment</u>
<u>Community-Based Corrections Programs Representative</u>				
Sue Horne ( /F) Fayetteville Area Sentencing 310 Green Street, Suite 110 Fay., NC 28301 323-5852	4/06	1st	April/09 4/30/09	Yes
<u>District Attorney</u>				
Ed Grannis (W/M) Cumberland County Courthouse 117 Dick Street Fay., NC 28301 678-2915(W)	6/04	4th	June/07 6/30/07	Yes
<u>Victim Services Programs Representative</u>				
Sharon Wright Hucks (B/F) Cumberland County District Attorney's Office Cumberland County Courthouse Fay., NC 28301 678-2915(W)	8/05	3rd	June/08 6/30/08	Yes
<u>At-Large</u>				
Kimbrell Tucker(W/F) CC Courthouse – Ste. 211 Fay., NC 28301 678-2901(W)	6/04	1st	June/07 6/30/07	Yes
Frederick H. Frimet (C/M) 1163 Bluebird Lane Fay., NC 28311 488-7486(H)	6/04	1st	June/07 6/30/07	Yes
Richard A. Hayes 332 Summertime Road Fay., NC 28303 484-0137/733-4564(W)	6/04	3rd	June/07 6/30/07	No
Carrie M. Heffney (B/F) 7665 Wilkins Drive Fay., NC 28311 488-0707/678-8351(W)	6/06	4th	June/09 6/30/09	Yes



CRIMINAL JUSTICE PARTNERSHIP ADVISORY BOARD PG. 3

<u>Name/Address</u>	<u>Date</u> Appointed	<u>Eligible For</u> Term	<u>Expires</u>	<u>Reappointment</u>
<u>At-Large</u>				
Ralph Spivey (W/M) 3113 Baker Street Fay., NC 28303 867-3201	6/04	2nd	June/07 6/30/07	No
Kirk Nance 603 Pilot Avenue Fay., NC 28303 484-4140/323-3500(W)	6/06	2nd	June/09 6/30/09	No
<u>Public Defender</u>				
Ron McSwain (W/M) Cumberland County Courthouse, Suite 307 117 Dick Street Fay., NC 28301 678-2918(W)	6/04	4th	June/07 6/30/07	Yes
<u>County Commissioner</u>				
Billy R. King (B/M) P.O. Box 1829 Fay., NC 28302 678-7771(W)	6/04	4th	June/07 6/30/07	Yes
Jeannette Council (B/F) P.O. Box 1829 Fay., NC 28302 678-7771(W)	10/06 (to fill unexpired term)	1st	June/09 6/30/09	Yes
<u>Substance Abuse Service Representative</u>				
James Miller (W/M) RR 1, Box 340 Hope Mills, NC 28348 485-6953	8/05	4th	June/08 6/30/08	Yes
<u>Criminal Defense Attorney</u>				
Sherry Miller 108 Hay Street Fay., NC 28301 485-5004(W)	6/04	1st	June/07 6/30/07	Yes

CRIMINAL JUSTICE PARTNERSHIP ADVISORY BOARD PG. 4

<u>Name/Address</u>	<u>Date Appointed</u>	<u>Term</u>	<u>Expires</u>	<u>Eligible For Reappointment</u>
<u>County Manager or Designee</u> Juanita Pilgrim (B/F) P.O. Box 1829 Fay., NC 28302 678-7723(W)	6/00	N/A	N/A	Yes

Meetings: Second Tuesday of Each Quarter, 5:30 PM, Cumberland County Day Reporting Center,  
412 W. Russell Street, Fayetteville, NC 28301-5548

APPLICANTS FOR  
CRIMINAL JUSTICE PARTNERSHIP ADVISORY BOARD

<u>NAME/ADDRESS/TELEPHONE</u>	<u>OCCUPATION</u>	<u>EDUCATIONAL BACKGROUND</u>
BAPTISTE, OSIRIS (M) 15 N. BRENDA STREET SPRING LAKE, NC 28390 496-3222/518-330-6560	RETIRED US ARMY	CRIMINAL JUSTICE
BRIGGS, BENITA Y. (B/F) 1116 BINGHAM DRIVE FAYETTEVILLE, NC 28304 822-1154/672-1294 (W)	OFFICE ASSISTANT IV	BA IN HISTORY; 08 GRAD – BA IN SOCIOLOGY
BROWN, KRAIG A. (B/M) 2909 WYCLIFFE COURT FAYETTEVILLE, NC 28306 426-3885/964-0503(W)	ARMY	BS – CRIMINAL JUSTICE MA – CRIMINAL JUSTICE
DAVIS, CHRISTOPHER (W/M) 7441 WILKINS DRIVE FAYETTEVILLE, NC 28311 482-4106/433-1825	POLICE OFFICE	BS, CRIMINAL JUSTICE M.P.A. – PUBLIC ADMIN
FLEMING, JOE (B/M) 7235 RYAN STREET FAYETTEVILLE, NC 28314 868-1428/257-7323 <b>**SERVES ON THE NURSING HOME ADVISORY BOARD**</b>	RETIRED	16 YEARS
IGUNBOR, GABRIEL, ESQ. (B/M) 1607 RAMSEY STREET FAYETTEVILLE, NC 28301 480-3007/635-5145(W)	CRIM. JUSTICE INSTRUCTOR	MASTER OF LAW
JACKSON, CRYSTAL EVE (B/F) 6422 KINCROSS AVENUE FAYETTEVILLE, NC 28304 426-3351	SITTER FOR THE ELDERLY	EXPECTED BA 12/07 IN CRIMINAL JUSTICE
JENSEN, LEESA (W/F) 719 ASHFIELD DRIVE FAYETTEVILLE, NC 28311 630-0253/433-1695(W)	HUMAN RELATIONS SPECIALIST	MASTERS: BUSINESS ADMINISTRATION
JOHNSON, LENNIE E. (W/M) 6360 SMITHFIELD WADE, NC 28395 980-1401	RETIRED – LAW ENFORCEMENT	SOME COLLEGE L.E. ACADEMY
MARSHALL, BARBARA SUMMEY (B/F) 7640 WILKINS DRIVE FAYETTEVILLE, NC 28311 488-2615/977-2303(W) <b>** SERVES ON BOARD OF HEALTH</b>	NAVY RESERVE CHAPLAIN	BA – PSYCHOLOGY MA – RELIGIOUS ED. DR. OF MINISTRY

CRIMINAL JUSTICE PARTNERSHIP ADVISORY BOARD APPLICANTS, Page 2

<u>NAME/ADDRESS/TELEPHONE</u>	<u>OCCUPATION</u>	<u>EDUCATIONAL BACKGROUND</u>
MCFADYEN, WILLIAM DAVID (W/M) 7122 HUNTERS POINT DRIVE FAYETTEVILLE, NC 28311 822-2362	RETIRED PART-TIME COURIER	ASSOCIATE DEGREE: BUSINESS ADMIN.
MERRITT, EDGAR F. (B/M) 1506 BOROS DRIVE FAYETTEVILLE, NC 28303 822-2976 <b>**SERVES ON THE ADULT CARE HOME COMM ADVISORY BOARD**</b>	RETIRED POLICE OFFICER	UNIVERSITY 1960-63
SULLIVAN, JOSEPH (Joe) (W/M) 2906 HIGH PLAINS DRIVE HOPE MILLS, NC 28348 717-1619/723-9227 (C)	SUBSTITUTE – RETIRED TEACHER	2 YR MASTERS
WEBB, BERNARD ( /M) P.O. BOX 70398 FT. BRAGG, NC 28307 630-3282/(336)402-1197	CITY LETTER CARRIER	AA – GEN. STUDIES BS – PSYCHOLOGY MA – HRD

KENNETH S. EDGE  
Chairman

J. BREEDEN BLACKWELL  
Vice Chairman

JEANNETTE M. COUNCIL  
JOHN T. HENLEY, JR.  
BILLY R. KING  
EDWARD G. MELVIN  
DIANE WHEATLEY



MARSHA S. FOGLE  
Clerk to the Board

MARIE COLGAN  
Deputy Clerk

**BOARD OF COMMISSIONERS**

5th Floor, New Courthouse • P.O. Box 1829 • Fayetteville, North Carolina 28302-1829  
(910) 678-7771 • Fax: (910) 678-7770

May 10, 2007

**May 21, 2007 Agenda Item**

TO: Board of Commissioners  
FROM: Marie Colgan, Deputy Clerk *MC*  
SUBJECT: Cumberland Co. Juvenile Crime Prevention Council Vacancy (1)

The Cumberland County Juvenile Crime Prevention Council has the following vacancy:

**Substance Abuse Professional:**

Lynett Shakeel – No longer able to serve on this Council. The Juvenile Crime Prevention Council is requesting that she be replaced by **Gregory T. Pitts** to fill her unexpired term.

I have attached the current membership and applicant list for this Council.

**PROPOSED ACTION: Make nomination to fill the vacancy (1).**

Attachments

cc: Sarah Hemingway, CCJPC Coordinator

CUMBERLAND COUNTY  
JUVENILE CRIME PREVENTION COUNCIL  
(Two year terms)

<u>Name/Address</u>	<u>Date Appointed</u>	<u>Term</u>	<u>Expires</u>	<u>Eligible For Reappointment</u>
<u>Local School Superintendent or designee</u>				
Carol Hudson Cumberland County Schools P.O. Box 2357 Fayetteville, North Carolina 28302 Phone: 678-2495	1/99			
<u>Chief of Police or designee</u>				
Lt. Sherry Sparks Fayetteville Police Department 467 Hay Street Phone: 433-1910	11/05			
<u>Local Sheriff or designee</u>				
Lt. Lynette Hodges Cumberland County Sheriff's Office 131 Dick Street Fayetteville, North Carolina 28301 Phone: 677-5474	1/07			
<u>District Attorney or designee</u>				
Cheri Siler-Mack Assistant District Attorney District Attorney's Office 117 Dick Street, Suite 427 Fayetteville, North Carolina 28301 Phone: 678-2915	1/99			
<u>Chief Court Counselor or designee</u>				
Joan Blanchard Department of Juvenile Justice P.O. Box 363 Fayetteville, North Carolina 28302 Phone: 678-2947	11/03			
<u>Director of Mental Health or designee</u>				
Debbie Jenkins Cumberland County Mental Health Center P.O. Box 3069 Fayetteville, North Carolina 28302 Phone: 323-0510	10/03			

Cumberland County Juvenile Crime Prevention Council Page 2

<u>Name/Address</u>	<u>Date Appointed</u>	<u>Term</u>	<u>Expires</u>	<u>Eligible For Reappointment</u>
<u>Director of Social Services or designee</u>				
Ms. Lee Roberts Child Protection and Placement Treatment Program Manager Cumberland County Department of Social Services P.O. Box 2429 Fayetteville, North Carolina 28302-2429 Phone: 677-2422	1/99			
<u>County Manager or designee</u>				
Juanita Pilgrim, Deputy Co. Mgr. Cumberland County Courthouse P.O. Box 1829 Fayetteville, North Carolina 28302-1829 Phone: 678-7726	1/99			
<u>Chief District Judge or designee</u>				
Judge Ed Pone P.O. Box 363 Fayetteville, North Carolina 28302 Phone: 678-2901	1/99			
<u>Health Director or designee</u>				
Archie Malloy Jail Health Administrator 205 Gillespie Street Fayetteville, North Carolina 28301 Phone: 672-5723	3/06			
<u>Parks and Recreation Representative</u>				
Melvin Lindsay City of Fayetteville Parks and Recreation Dept. 433 Hay Street Fayetteville, North Carolina 28301 Phone: 433-1547	2/05			
<u>County Commissioner</u>				
Billy R. King P.O. Box 1829 Fayetteville, NC 28302-1829 Phone: 678-7771	1/99			

Cumberland County Juvenile Crime Prevention Council, Page 3

<u>Name/Address</u>	<u>Date Appointed</u>	<u>Term</u>	<u>Expires</u>	<u>Eligible For Reappointment</u>
<u>Substance Abuse Professional</u>				
Lynett Shakeel CC Mental Health 109 Bradford Avenue Fayetteville, NC 28301 222-6093(W)	8/05	1st	Aug/07 8/31/07	Yes
<u>Member of Faith Community</u>				
Rev. Brian Thompson 3942 Gaithersburg Lane Hope Mills, NC 28348 436-2462/867-2708(W)	5/05	1st	May/07 5/31/07	Yes
<u>Person Under Age 21</u>				
Shakeema Burns 1317 Alexwood Drive Hope Mills, NC 28348 423-0180	8/04	2nd	Aug/06 8/31/06	No
<u>Juvenile Defense Attorney</u>				
Beth A. Hall 4508 Weaverhall Drive Fayetteville, NC 28314 257-0847(Cell)	9/06	1st full	Aug/08 8/31/08	Yes
<u>Member of Business Community</u>				
Gene Hallock 173 Aloha Drive Fayetteville, NC 28311 822-5409	8/05	1st	Aug/07 8/31/07	Yes
<u>United Way or Non-Profit</u>				
Margarita Dostall CC Schools P.O. Box 2357 Fayetteville, NC 28302 678-2300	2/06	2nd	Jan/08 1/31/08	No
<u>At Large Representatives</u>				
Henry Berry 1722 Eldridge Street Fayetteville, North Carolina 28301 Phone: 396-5521	8/04	2nd	Aug/06 8/31/06	No



Cumberland County Juvenile Crime Prevention Council, Page 4

<u>Name/Address</u>	<u>Date Appointed</u>	<u>Term</u>	<u>Expires</u>	<u>Eligible For Reappointment</u>
John Clark Juvenile Assessment Center 121 Lamon Street Fayetteville, North Carolina 28301 Phone: 323-5070/433-1116	9/06	1st full	Aug/08 8/31/08	Yes
Dr. Polly Davis FTCC P.O. Box 35236 Fayetteville, North Carolina 28303 Phone: 678-8322	6/05	1st	Aug/07 8/31/07	Yes
Ron Snyder 7008 Hounds Ear Court Fayetteville, North Carolina 28311 Phone: 488-1388	6/05	2nd	Aug/07 8/31/07	No
Sue Thomas 3741 Harrisburg Drive Fayetteville, North Carolina 28306 Phone: 425-8868	6/05	1st	Aug/07 8/31/07	Yes
Patrick Hurley, Director Workforce Development Center P.O. Box 1829 Fayetteville, North Carolina 28302 Phone: 484-3044/323-3421(W)	8/05	2nd	Aug/07 8/31/07	No
Krista Hancock 4H Agent – Cooperative Extension 301 E. Mountain Drive Fayetteville, North Carolina 28306 Phone: 321-6867	4/06	2nd	Apr/08 4/30/08	No

Non-Voting Member

Cindy Holmes  
DJJDP Regional Consultant  
108 N. Orange Street  
Dunn, North Carolina 28334  
Phone: 919-733-3388(W)

Meetings: Second Wednesday of each month at 8:00 AM. CC CommuniCare Conference Room – 711B Executive Place

Contact: Sarah Hemingway – Phone: 829-9017 - Fax: 485-4752

APPLICANTS FOR  
JUVENILE CRIME PREVENTION COUNCIL

<u>NAME/ADDRESS/TELEPHONE</u>	<u>OCCUPATION</u>	<u>EDUCATIONAL BACKGROUND</u>
ABERCROMBIE, KALISHA (B/F) 3804 CASPER STREET HOPE MILLS, NC 28348 797-2537/864-7230(W) <b>**SERVES ON THE COMMUNITY CHILD PROTECTION FATALITY PREVENTION TEAM**</b>	DIRECT CARE PROVIDER AT RESIDENTIAL GROUP HOME	WORKING ON ASSOCIATE DEGREE
BAPTISTE, OSIRIS ( /M) 15 N. BRENDA STREET SPRING LAKE, NC 28390 496-3222/518-330-6560	RETIRED US ARMY	CRIMINAL JUSTICE
BRIGGS, BENITA Y. (B/F) 1116 BINGHAM DRIVE FAYETTEVILLE, NC 28304 822-1154/672-1294 (W)	OFFICE ASSISTANT IV	BA IN HISTORY; 08 GRAD – BA IN SOCIOLOGY
BROWN, KRAIG A. (B/M) 2909 WYCLIFFE COURT FAYETTEVILLE, NC 28306 426-3885/964-0503 (W)	ARMY	BS – CRIMINAL JUSTICE MA – CRIMINAL JUSTICE
CARTER, JAMES M. (W/M) 1212 CASTLEROCK DRIVE FAYETTEVILLE, NC 28304 484-4550/678-9896 (W)	PART-TIME TEACHER MEDIA PRODUCTION	BS - COMMUNICATIONS MINOR IN ART CONTINUING EDUC.
DAVIS, CHRISTOPHER (W/M) 7441 WILKINS DRIVE FAYETTEVILLE, NC 28311 482-4106/433-1825	POLICE OFFICE	BS, CRIMINAL JUSTICE M.P.A. – PUBLIC ADMIN
DILLON, MARY E. ( /F) 3209 MCCHOEN DRIVE FAYETTEVILLE, NC 28301 822-2045/678-8348(W)	BASIC SKILLS INSTRUCTOR	BS – ELEM. EDUCATION
FENNER, SHANESSA L. (B/F) 5710-08 IVANHOE COURT FAYETTEVILLE, NC 28314 487-9603/436-4381(W)	PRINCIPAL	BA – ELEM. EDUCATION MA – ELEM. EDUCATION MSA – SCHOOL ADMIN.
FLEMING JR., REV. JOE B/M) 7235 RYAN STREET FAYETTEVILLE, NC 28314 868-1428/583-1695	MINISTER	16 YEARS  <b>**SERVES ON THE NURSING HOME ADVISORY BOARD**</b>
HAIR, ANTHONY D. (B/M) 6344 MURPHY ROAD STEDMAN, NC 28391 323-9176/592-1575(W)	CONSUMER SOLUTIONS REPRESENTATIVE	BS EDUCATION

JUVENILE CRIME PREVENTION COUNCIL APPLICANTS, PAGE 2

EDUCATIONAL

<u>NAME/ADDRESS/TELEPHONE</u>	<u>OCCUPATION</u>	<u>BACKGROUND</u>
INGRAM, JAMES (B/M) PO BOX 87671 FAYETTEVILLE, NC 28304 257-1831/488-8415(W) <b>**SERVES ON THE ADULT CARE HOME COMMUNITY ADVISORY COUNCIL**</b>	ASST. PRINCIPAL	POST GRADUATE
JACKSON, CRYSTAL EVE (B/F) 6422 KINCROSS AVENUE FAYETTEVILLE, NC 28304 426-3351	SITTER FOR THE ELDERLY	EXPECTED BA 12/07 IN CRIMINAL JUSTICE
JENSEN, LEESA (W/F) 719 ASHFIELD DRIVE FAYETTEVILLE, NC 28311 630-0253/433-1695(W)	HUMAN RELATIONS SPECIALIST	MASTERS: BUSINESS ADMINISTRATION
KELLER, BEVERLY N. (B/F) 7721 DUNDENNON DRIVE FAYETTEVILLE, NC 28306 867-7009/485-8326(W)	REALTOR/BROKER	STUDENT:MAJOR CRIMINAL JUSTICE
MACK, DAVID J. (B/M) 5479 LYNBROOK COURT FAYETTEVILLE, NC 28314 867-1214 <b>**SERVES ON THE EQUALIZATION &amp; REVIEW BOARD**</b>	RETIRED SCHOOL ADMINISTRATOR	MS – SCHOOL ADMIN.
MARSHALL, BARBARA SUMMEY (B/F) 7640 WILKINS DRIVE FAYETTEVILLE, NC 28311 488-2615/977-2303(W) <b>**SERVES ON THE BOARD OF HEALTH**</b>	NAVY RESERVE CHAPLAIN	BA – PSYCHOLOGY MA – RELIGIOUS ED. DR. OF MINISTRY
MATTHEWS, GEORGE (B/M) 6984 KINGS LYNN LOOP FAYETTEVILLE, NC 28304 487-3904/396-8169	GOVT. CONTRACT EMPLOYEE	BS – AERONAUTICS MA – HUMAN RELATIONS
MOORE, SYLVIA L. (B/F) 1115 LANDAU ROAD FAYETTEVILLE, NC 28311 822-4493/584-4553 (C)	RETIRED TEACHER	BS/MASTER – ELEMENTARY EDUCATION
MURRAY, JEFFREY W. (W/M) 4743 DENTON COURT FAYETTEVILLE, NC 28306 425-7046/977-6180 (W)	CONSULTANT	MS/BS/AA
POPE, RITA J. (B/F) 679 BARTON'S LAND PL #4 FAYETTEVILLE, NC 28314 864-4993	RETIRED JAILER	SOME COLLEGE

JUVENILE CRIME PREVENTION COUNCIL APPLICANTS, PAGE 3

EDUCATIONAL

NAME/ADDRESS/TELEPHONE

OCCUPATION

BACKGROUND

SALLEY, LUKE (B/M)  
104 UNIVERSITY AVENUE  
FAYETTEVILLE, NC 28301  
364-8505/483-0121 (W)

RETIRED CORRECTIONAL  
CAPTAIN

BA – ECONOMICS &  
ACCOUNTING

SULLIVAN, JOSEPH (Joe) (W/M)  
2906 HIGH PLAINS DRIVE  
HOPE MILLS, NC 28348  
717-1619/723-9227 (C)

SUBSTITUTE – RETIRED  
TEACHER

2 YR MASTERS

THOMPSON-PINCKNEY, TERESA (AA/F)  
472 BRANDERMILL ROAD  
FAYETTEVILLE, NC 28314  
867-7409

HIGH EDUCATION  
ADMINISTRATOR

BA-CRIMINOLOGY &  
CRIMINAL JUSTICE  
MA-SOCIOLOGY

WEBB, BERNARD ( /M)  
P.O. BOX 70398  
FT. BRAGG, NC 28307  
630-3282/(336)402-1197

CITY LETTER CARRIER

AA – GENERAL STUDIES  
BS – PSYCHOLOGY  
MA – HRD

WIGGS, CECIL (W/M)  
6213 STONEY POINT LOOP  
FAYETTEVILLE, NC 28306  
425-8557

RETIRED SCHOOL  
TEACHER

MASTERS -EDUCATION

KENNETH S. EDGE  
Chairman

J. BREEDEN BLACKWELL  
Vice Chairman

JEANNETTE M. COUNCIL  
JOHN T. HENLEY, JR.  
BILLY R. KING  
EDWARD G. MELVIN  
DIANE WHEATLEY

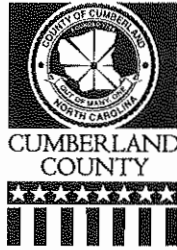

ITEM NO.

36

MARSHA S. FOGLE  
Clerk to the Board

MARIE COLGAN  
Deputy Clerk

**BOARD OF COMMISSIONERS**

5th Floor, New Courthouse • P.O. Box 1829 • Fayetteville, North Carolina 28302-1829  
(910) 678-7771 • Fax: (910) 678-7770

May 8, 2007

**May 21, 2007 Agenda Item**

**MEMORANDUM**

TO: Board of Commissioners

FROM: Marie Colgan, Deputy Clerk *MC*

SUBJECT: Fayetteville Technical Community College Board of Trustees  
Vacancy (1)

The Fayetteville Technical Community College Board of Trustees will have the following vacancy on June 30, 2007.

**William S. Wellons, Jr.** – Completing first term. Eligible for reappointment.

I have attached the current membership list and applicant list for this Board.

**PROPOSED ACTION:** Make nomination to fill the vacancy (1).

cc: Dr. Larry Norris

*Celebrating Our Past... Embracing Our Future*

FAYETTEVILLE TECHNICAL COMMUNITY COLLEGE  
BOARD OF TRUSTEES  
(County Appointees)  
4 Year Terms

<u>Name/Address</u>	<u>Date Appointed</u>	<u>Term</u>	<u>Expires</u>	<u>Eligible For Reappointment</u>
Lula Crenshaw (B/F) 878 Sunbury Drive Fayetteville, NC 28311 488-5549	5/06	2nd	June/10 6/30/10	No
William S. Wellons, Jr. (W/M) P.O. Box 766 Spring Lake, NC 28390 868-5435/436-3131(W)	5/03	1st	June/07 6/30/07	Yes
Thornton W. Rose (W/M) 2614 Mirror Lake Drive Fayetteville, NC 28303 484-9060	5/04	2nd	June/08 6/30/08	No
Harry F. Shaw (W/M) 1225 Haymount Court Fayetteville, NC 28305 484-6737	6/05	1st	June/09 6/30/09	Yes

Contact person: Betty Shackelford 678-8222  
PO Box 35236, Fay NC 28303  
Fax # 678-8269  
e-mail: shackelb@faytechcc.edu

Meetings: Board has been meeting the 3rd Monday of each month at 12:45 pm. No meetings in July or December. (Once each quarter required by bylaws) -written notification sent for all regularly-called meetings.

\* Terms extended by the General Assembly.

APPLICANTS FOR  
FTCC BOARD OF TRUSTEES

<u>NAME/ADDRESS/PHONE</u>	<u>OCCUPATION</u>	<u>EDUCATIONAL BACKGROUND</u>
ALLEN, CHARLES (W/M) 2233 WILMINGTON HIGHWAY FAYETTEVILLE, NC 28306 483-3213/323-8811(W)	OWNER- LANDSCAPING COMPANY	NURSERY & HORTICULTURE STUDIES
ANDERSON, LARRY D. (AA/M) 7669 WILKINS DRIVE FAYETTEVILLE, NC 28311 488-6099/396-8991 (W)	PASTOR & CHEMICAL BIOLOGICAL, NUCLEAR, & RADIOLOGICAL DEFENSE INSTRUCTOR	BS – PSYCHOLOGY MPA- ENVIRONMENTAL MANAGEMENT
ANDREWS-McCALL, MAXINE (B/F) 5637 MUM CREEK LANE FAYETTEVILLE, NC 28304 423-1727/322-5800 (C)	RETIRED	DOCTORATE IN EDUC. ADMINISTRATION
CHAVIS, DR. ANNIE M. (B/F) 3454 THORNDIKE DRIVE FAYETTEVILLE, NC 28311 488-9555/672-1852(W)	COLLEGE PROFESSOR	
CHESTNUTT, A. JOHNSON (W/M) 578 MILDEN ROAD FAYETTEVILLE, NC 28314 484-6365/323-1040(W)	ACCOUNTANT	BS/BA
CHISOLM, ALICIA S. (AA/F) 1855 CASCADE STREET FAYETTEVILLE, NC 28301 488-7820/488-5935 (W) <b>**SERVES ON THE CIVIC CENTER COMMISSION**</b>	SELF EMPLOYED RETIRED DOA CIVILIAN	MBA & BS – BUSINESS ADMIN/MGT
GABRIEL, GRANT (W/M) 3690 RAEBURN COURT FAYETTEVILLE, NC 28314 678-8995/907-0203 (W)	EDUCATOR ADMINISTRATOR	BS, MS, M. ED, ED. D
IGUNBOR, GABRIEL, ESQ. (B/M) 1607 RAMSEY STREET FAYETTEVILLE, NC 28301 480-3007/635-5145(W)	CRIM. JUSTICE INSTRUCTOR	MASTER OF LAWS
JOHANNES, ULRICH (W/M) 516 THORNGATE DRIVD FAYETTEVILLE, NC 28303 864-0420/433-1718(W)	ASSOC. NETWORK ADMINISTRATOR	BACHELORS – INFORMA- TION TECHNOLOGY
LEE, DELMAR T. (B/M) 7112 AVILA DRIVE FAYETTEVILLE, NC 28314 864-5482	RETIRED SUBSTITUTE TEACHER	AS – AVIONICS BS/MS/EDUCATION

FTCC BOARD OF TRUSTEES APPLICANTS, PAGE 2

EDUCATIONAL NAME/ADDRESS/PHONE	OCCUPATION	BACKGROUND
LEWIS, BOB (W/M) 3011 BANKHEAD DRIVE FAYETTEVILLE, NC 28306 426-6999	RETIRED EDUCATOR	BS, MASTERS
LEWIS, SHERYL J. (W/F) 3011 BANKHEAD DRIVE FAYETTEVILLE, NC 28306 426-6999	RETIRED EDUCATOR	BA, MA, ED.S.
MATTHEWS, GEORGE E. (B/M) 6984 KINGS LYNN LOOP FAYETTEVILLE, NC 28304 487-3904/396-8169/2227	GOVT. CONTRACT EMPLOYEE	BS – AERONAUTICS MA – HUMAN RELATIONS
MCCUNE, DAVID JR. (W/M) 4801 RESEARCH DRIVE FAYETTEVILLE, NC 28306 297-6034	VICE PRESIDENT MCCUNE TECHNOLOGY	SOME COLLEGE
MURRAY, JEFFREY W. (W/M) 4743 DENTON COURT FAYETTEVILLE, NC 28306 425-7046/977-6180 (W)	CONSULTANT	MS/BS/AA
SALLEY, LUKE (B/M) 104 UNIVERSITY AVENUE FAYETTEVILLE, NC 28301 364-8505/483-0121 (W)	RETIRED CORRECTIONAL CAPTAIN	BA – ECONOMICS & ACCOUNTING
THOMPSON-PINCKNEY, TERESA (AA/F) 472 BRANDERMILL ROAD FAYETTEVILLE, NC 28314 867-7409	HIGH EDUCATION ADMINISTRATOR	BA-CRIMINOLOGY & CRIMINAL JUSTICE MA-SOCIOLOGY
WADDLE, ROBERTA (W/F) 3941 GAINNEY ROAD FAYETTEVILLE, NC 28306 484-7936	SEMI RETIRED	BS –BIOLOGY ED. MS – BOTANY ASSOC – EDP
WENDELKEN, DAVID ( /M) 818 AZALEA DRIVE FAYETTEVILLE, NC 28301 677-0495/223-2417(W)	CONSULTANT	BA – POLITICAL SCIENCE
WILLIFORD, P. (PAT)(W/M) 951 S. MCPHERSON CHURCH ROAD FAYETTEVILLE, NC 28303 223-0223/484-2168 (W)	CPA	BS/BA

**\*\*SERVES ON THE MENTAL HEALTH BOARD\*\***



KENNETH S. EDGE  
Chairman

J. BREEDEN BLACKWELL  
Vice Chairman

JEANNETTE M. COUNCIL  
JOHN T. HENLEY, JR.  
BILLY R. KING  
EDWARD G. MELVIN  
DIANE WHEATLEY

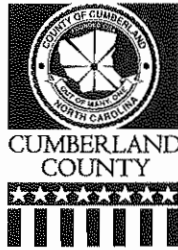

ITEM NO. 3H

MARSHA S. FOGLE  
Clerk to the Board

MARIE COLGAN  
Deputy Clerk

**BOARD OF COMMISSIONERS**

5th Floor, New Courthouse • P.O. Box 1829 • Fayetteville, North Carolina 28302-1829  
(910) 678-7771 • Fax: (910) 678-7770

May 8, 2007

**June 6, 2005 Agenda Item**

TO: Board of Commissioners  
FROM: Marie Colgan, Deputy Clerk  
SUBJECT: Human Relations Commission Vacancies (2)

The Human Relations Commission will have the following vacancies on July 1, 2007.

**Lynette Hill Gardner** – Completing first term. Eligible for reappointment.

**Densie Giles** – Completing first term. Eligible for reappointment.

I have attached the current County membership list and applicant list for this commission.

**PROPOSED ACTION:** Make nominations to fill the vacancies (2).

cc: Ron McElrath - Human Relations Director

*Celebrating Our Past... Embracing Our Future*

HUMAN RELATIONS COMMISSION  
 (County Commissioner Appointees)  
 2Year Term

Name/Address	Date Appointed	Term	Expires	Eligible for Reappointment
Cornelius Williams (B/M) 1327 Four Wood Drive Fayetteville, NC 28312 484-5044	11/06	1 <sup>st</sup>	Nov/09 11/01/09	Yes
Zeandrew Farrow 403 Virginia Avenue Spring Lake, NC 28390 257-8570 (Cell)	10/06	2 <sup>nd</sup>	Nov/08 11/01/08	No
Lynette Hill Gardner (B/F) 3217 Hennardland Place Hope Mills, NC 28348 424-5787/822-9963(W)	6/05	1 <sup>st</sup>	July/07 07/01/07	Yes
Denise Giles(W/F) 1062 Center Street Fayetteville, NC 28306 485-8079/826-2454, ext.22(W)	6/05	1 <sup>st</sup>	July/07 07/01/07	Yes

Contact: Ronald McElrath – 433-1625 – Fax # 433-1535  
 Human Relations Director  
 City of Fayetteville

Meetings: 2<sup>nd</sup> Thursday of every month – 5:30 pm  
 City Hall – Lafayette Room

APPLICANTS FOR  
HUMAN RELATIONS COMMISSION

<u>NAME/ADDRESS/PHONE</u>	<u>OCCUPATION</u>	<u>EDUCATIONAL BACKGROUND</u>
BRIGGS, BENITA Y. (B/F) 1116 BINGHAM DRIVE FAYETTEVILLE, NC 28304 822-1154/672-1294 (W)	OFFICE ASSISTANT IV	BA IN HISTORY; 08 GRAD – BA IN SOCIOLOGY
CHISOLM, ALICIA S. (A/F) 1855 CASCADE STREET FAYETTEVILLE, NC 28301 488-7820/488-5935 (W) <b>**SERVES ON THE CIVIC CENTER COMMISSION**</b>	SELF EMPLOYED RETIRED DOA CIVILIAN	MBA & BS – BUSINESS ADMIN/MGT
FLEMING JR, DR. REV. JOE (B/M) 7235 RYAN STREET FAYETTEVILLE, NC 28314 868-1428/583-1695 <b>**SERVES ON THE NURSING HOME ADVISORY BOARD**</b>	RETIRED	16 YEARS
GABRIEL, GRANT (W/M) 3690 RAEBURN COURT FAYETTEVILLE, NC 28314 678-8995/907-0203 (W)	EDUCATOR ADMINISTRATOR	BS, MS, M. ED, ED. D
HALL, BARBARA M. (W/F) 1305 SKYLINE DRIVE FAYETTEVILLE, NC 28314 495-0603/483-8970 (W)	EXECUTIVE DIRECTOR OF CONTACT	BA – SOCIOLOGY (2007) MS IN HUMAN SVS
HUMPHREY, HORACE (B/M) 1852 CASCADE STREET FAYETTEVILLE, NC 28301 488-5143/850-5170 (CELL)	RETIRED	BACHELOR OF SCIENCE
LANGLEY, MARGO (B/F) 974-3 STEWARTS CREEK DRIVE FAYETTEVILLE, NC 28314 864-1169/919-662-2800/919-856-5920(W)	DETENTION OFFICER	AA DEGREE + COURSES
LOWE, CLABON RODELL (B/M) 512 KENTWELL COURT FAYETTEVILLE, NC 28303 864-7145/396-5710/5663(W)	US ARMY	2 YR DEGREE
McNEILL, TERESA RENA (B/F) 3518 PICKEREL STREET FAYETTEVILLE, NC 28306 480-0313/483-3648 x1109 (W) <b>**SERVES ON THE ADULT CARE HOME COMMUNITY ADV. BOARD**</b>	RE-EXAM TECH HOUSING AUTHORITY	HS; SOME TECH COLLEGE
NIXON, GREGORY (B/M) 713 HOPE MILLS RD # 242 FAYETTEVILLE, NC 28304 826-4745/527-4745 (W)	OWNER – CLEANING BUSINESS	3 YRS OF COLLEGE

HUMAN RELATIONS COMMISSION APPLICANTS, Page 2

<u>NAME/ADDRESS/PHONE</u>	<u>OCCUPATION</u>	<u>EDUCATIONAL BACKGROUND</u>
POPE, RITA J. (B/F) 679 BARTON'S LAND PL #4 FAYETTEVILLE, NC 28314 864-4993	RETIRED JAILER	SOME COLLEGE
SPAIN, PHYLLIS M. (B/F) PO BOX 821 SPRING LAKE, NC 28390 484-4726/916-4974 (W) <b>**SERVES ON THE MENTAL HEALTH BOARD**</b>	MINISTER/CHAPLAIN	DOCTORATE OF MINISTRY CLINICAL PASTORAL ED.
YEPEZ, JOSE ( /M) 3900 FOSTER DRIVE FAYETTEVILLE, NC 28311 488-4423/728-8660	RETIRED	BS-BUSINESS AS-PUBLIC ADMIN



KENNETH S. EDGE  
Chairman  
  
J. BREEDEN BLACKWELL  
Vice Chairman  
  
JEANNETTE M. COUNCIL  
JOHN T. HENLEY, JR.  
BILLY R. KING  
EDWARD G. MELVIN  
DIANE WHEATLEY

**BOARD OF COMMISSIONERS**  
5th Floor, New Courthouse • P.O. Box 1829 • Fayetteville, North Carolina 28302-1829  
(910) 678-7771 • Fax: (910) 678-7770

May 8, 2007

**May 21, 2007 Agenda Item**

TO: Board of Commissioners  
FROM: Marie Colgan, Deputy Clerk *MC*  
SUBJECT: Jury Commission Vacancy (1)

The Jury Commission will have the following vacancy on June 30, 2007:

**Monika Simmons** – Completing first term. Eligible for reappointment.

I have attached the current membership list and applicant list for this board.

**PROPOSED ACTION: Make nomination to fill the vacancy (1).**

Attachments

cc: Ellen B. Hancox, Trial Court Administrator

## JURY COMMISSION

## 2 Year Term

<u>Name/Address</u>	<u>Date Appointed</u>	<u>Term</u>	<u>Expires</u>	<u>Eligible For Reappointment</u>
Monika Simmons (/F) 1812 Charity Lane Fayetteville, NC 28304 273-4595 (cell)	6/05	1st	June/07 6/30/07	Yes

Elvin Steve McDaniel – Clerk of Court’s appointee  
4500 Ewe Court  
Fayetteville, North Carolina 28304

Mabel Smith – Judge Johnson’s appointee

(The other two are appointed (1) by the Senior Resident Superior Court Judge and (1) by the Clerk of Superior Court.)

Contact: Ellen B. Hancox, Trial Court Administrator – 321-3841, fax # 678-2975

No regular meeting schedule.

APPLICANTS FOR  
JURY COMMISSION

<u>NAME/ADDRESS/TELEPHONE</u>	<u>OCCUPATION</u>	<u>EDUCATIONAL BACKGROUND</u>
ANDREWS-McCALL, MAXINE (B/F) 5637 MUM CREEK LANE FAYETTEVILLE, NC 28304 423-1727/322-5800 (C)	RETIRED	DOCTORATE IN EDUC. ADMINISTRATION
CAMPBELL, REBECCA (W/F) 7027 DARNELL STREET FAYETTEVILLE, NC 28314 487-1555/432-6393 (W)	DIRECTOR FT BRAGG DEPT. OF EDUC AND LIBRARIES	Ed.D – SPECIAL EDUC.
DILLON, MARY E. ( /F) 3209 MCCHOEN DRIVE FAYETTEVILLE, NC 28301 822-2045/678-8348(W)	BASIC SKILLS INSTRUCTOR	BS – ELEM. EDUCATION/ COLLEGE TEACHING
FLEMING JR., REV. JOE B/M) 7235 RYAN STREET FAYETTEVILLE, NC 28314 868-1428/583-1695	MINISTER	16 YEARS
<b>**SERVES ON THE NURSING HOME ADVISORY BOARD**</b>		
IGUNBOR, GABRIEL, ESQ. (B/M) 1607 RAMSEY STREET FAYETTEVILLE, NC 28301 480-3007/635-5145(W)	CRIM. JUSTICE INSTRUCTOR	MASTER OF LAW
POPE, RITA J. (B/F) 679 BARTON'S LAND PL #4 FAYETTEVILLE, NC 28314 864-4993	RETIRED JAILER	SOME COLLEGE
SUBLETT, KIMBERLY R. (W/F) 4517 HEADWIND DRIVE FAYETTEVILLE, NC 28306 424-9524/609-0677	SYSTEMS ANALYST	B.S. – BUS. ADMIN MGT.
WEBB, BERNARD ( /M) P.O. BOX 70398 FT. BRAGG, NC 29807 630-3282/(336)402-1197	CITY LETTER CARRIER	AA – GEN. STUDIES BS – PSYCHOLOGY MA – HRD

ITEM NO. 3J

KENNETH S. EDGE  
Chairman

J. BREEDEN BLACKWELL  
Vice Chairman

JEANNETTE M. COUNCIL  
JOHN T. HENLEY, JR.  
BILLY R. KING  
EDWARD G. MELVIN  
DIANE WHEATLEY



MARSHA S. FOGLE  
Clerk to the Board

MARIE COLGAN  
Deputy Clerk

**BOARD OF COMMISSIONERS**

5th Floor, New Courthouse • P.O. Box 1829 • Fayetteville, North Carolina 28302-1829  
(910) 678-7771 • Fax: (910) 678-7770

May 8, 2007

**May 21, 2007 Agenda Item**

TO: Board of Commissioners  
FROM: Marie Colgan, Deputy Clerk *MC*  
SUBJECT: Nursing Home Advisory Board Vacancies (1)

The Nursing Home Advisory Board has the following vacancy:

Navy Thomas - Completes her initial term on 6-30-07, but due to her attendance, Adult Care is requesting that she be replaced with **Stephanie Hodges**.

I have attached the current membership and applicant lists for this board.

**PROPOSED ACTION: Make nomination to fill the vacancy (1).**

Attachments

cc: Andrea Wright-Valdez, Mid-Carolina Area Agency on Aging

*Celebrating Our Past...Embracing Our Future*



NURSING HOME ADVISORY BOARD  
3 Year Term  
(Initial Appointment One Year)

<u>Name/Address</u>	<u>Date</u> <u>Appointed</u>	<u>Term</u>	<u>Expires</u>	<u>Eligible For</u> <u>Reappointment</u>
Mandella Edwards ( /F) 4151 Village Drive Fayetteville, NC 28304 429-0790(H)	4/07	1 <sup>st</sup>	April/10 4/30/10	Yes
Rev. Dr. Joe Fleming (B/M) 7235 Ryan Street Fayetteville, NC 28314 864-9084/257-7323(W)	6/06	1st	June/09 6/30/09	Yes
Martha McKoy P.O. Box 42152 Fayetteville, NC 28309 423-0771	9/05	1st	Sept/08 9/30/08	Yes
Edgar F. Merritt (B/M) 1506 Boros Drive Fayetteville, NC 28303 822-2976/286-2552 (W)	12/06	Initial	Dec/07 12/31/07	Yes
William R. Nichols(W/M) 1240 Magnolia Church Road Stedman, NC 28391 483-3934/433-1924(W)	2/07	1 <sup>st</sup>	Feb/10 2/28/10	Yes
Hervenna Pannell (B/F) 1821 Eichelberger Drive Fayetteville, NC 28303 822-8516/907-9355(W)	2/06	1st	Feb/09 2/28/09	Yes
Robert Pringle (B/M) 1835 Cascade Street Fayetteville, NC 28301 483-7547	10/04	2nd	Oct/07 10/31/07	No
Dr. Kathleen Radcliff(W/F) P.O. Box 53004 Fayetteville, NC 28305 484-4895/868-8153(W)	1/06	1st	Jan/09 1/31/09	Yes
Barbara Randolph (W/F) P.O. Box 36113 Fayetteville, NC 28303 484-3602 (H)	4/06	1st	April/09 4/30/09	Yes

Nursing Home Advisory Board, page 2

<u>Name/Address</u>	<u>Date Appointed</u>	<u>Term</u>	<u>Expires</u>	<u>Eligible For Reappointment</u>
Navy Thomas (B/F) 7208 Reedy Creek Drive Fayetteville, NC 28314 867-4531/483-2222(W)/224-1332(Cell)	6/06	Initial	June/07 6/30/07	Yes
Lora L. Watson 1516 Chedington Road Hope Mills, NC 28348 485-3558/824-0993	4/07	2 <sup>nd</sup>	April/10 4/30/10	No

CONTACT: Andrea Wright-Valdez, Mid-Carolina Area Agency on Aging  
P. O. Box 1510, Fayetteville, NC 28302, (Phone: 323-4191, ext. 25)

Quarterly, (March, June, September & December) at 10:00 AM on the first Wednesday - at various nursing homes in the county.

APPLICANTS FOR  
NURSING HOME ADVISORY BOARD

<u>NAME/ADDRESS/TELEPHONE</u>	<u>OCCUPATION</u>	<u>EDUCATIONAL BACKGROUND</u>
ADAMS, TIFFANY M. (B/F) 1123 CURRY FORD DRIVE FAYETTEVILLE, NC 28314 867-5976/286-1061(W) <b>**SERVES ON THE ADULT CARE HOME COMMUNITY ADVISORY COMMITTEE**</b>	CHURCH MUSICIAN SALES ASSOCIATE	GRADUATING FSU SPRING '06
HAMMOND, CLYDE E. (W/M) 1802 FLINTSHIRE ROAD FAYETTEVILLE, NC 28304 425-2774	RETIRED – VOLUNTEER HOSPICE CHAPLAIN	BACHELORS DEGREE
LLOYD, TOM (W/M) 1306 BERKSHIRE ROAD FAYETTEVILLE, NC 28305 484-6762/678-7618(W)	PLANNING DIRECTOR	BA, MA – GEOGRAPHY/ PLANNING MINOR- PSYCHOLOGY & STATISTICS
McNEILL, TERESA RENA (B/F) 3518 PICKEREL STREET FAYETTEVILLE, NC 28306 480-0313/483-3648 x1109 (W) <b>**SERVES ON THE ADULT CARE HOME COMMUNITY ADV. BOARD**</b>	RE-EXAM TECH HOUSING AUTHORITY	HS; SOME TECH COLLEGE
WOLFE, JACQUELINE B. (W/F) 1812 MANCHESTER STREET FAYETTEVILLE, NC 28303 484-8588/484-5146 (W) <b>**SERVES ON THE ADULT CARE HOME COMMUNITY ADV. BOARD**</b>	MEMBER SERVICES REP	HS; SOME TECH COURSES

KENNETH S. EDGE  
Chairman

J. BREEDEN BLACKWELL  
Vice Chairman

JEANNETTE M. COUNCIL  
JOHN T. HENLEY, JR.  
BILLY R. KING  
EDWARD G. MELVIN  
DIANE WHEATLEY



ITEM NO. 3K  
MARSHA S. FOGLE  
Clerk to the Board  
MARIE COLGAN  
Deputy Clerk

**BOARD OF COMMISSIONERS**

5th Floor, New Courthouse • P.O. Box 1829 • Fayetteville, North Carolina 28302-1829  
(910) 678-7771 • Fax: (910) 678-7770

May 8, 2007

**May 21, 2007 Agenda Item**

TO: Board of Commissioners  
FROM: Marie Colgan, Deputy Clerk *MC*  
SUBJECT: Parks and Recreation Advisory Commission Vacancies (3)

The Parks and Recreation Advisory Commission will have the following vacancies on June 30, 2007:

**Willie Cooper, Jr.** – Completing first term. Eligible for reappointment.

**Paul Douglas Caudill** – Completing first term. Eligible for reappointment.

**Lynette Hill Gardner** – Completing first term. Eligible for reappointment.

I have attached the current membership list and applicant list for this board.

**PROPOSED ACTION: Make nominations to fill the vacancies (3).**

Attachments

cc: Robert Barefoot  
City of Fayetteville

*Celebrating Our Past...Embracing Our Future*

PARKS & RECREATION  
ADVISORY BOARD

2 & 3 Year Terms

Name/Address	<u>Date</u> Appointed	Term	Expires	<u>Eligible For</u> Reappointment
Tom Cain (C/M) 2786 Baywood Road Fayetteville, NC 28312 630-3970	6/05	1 <sup>st</sup>	June/08 6/30/08	Yes
Paul Douglas Caudill (W/M) 5325 South Forty Drive Hope Mills, NC 28348 486-0015/424-8589(W)	6/05	1 <sup>st</sup>	June/07 6/30/07	Yes
Willie Cooper, Jr. (B/M) 5599 Ashgrove Drive Fayetteville, NC 28311 488-4037/829-9873(W)	8/05	1 <sup>st</sup>	June/07 6/30/07	Yes
Lynette Hill Gardner (B/F) 1530 Rosebud Drive Fayetteville, NC 28311 424-5787/822-9963(W)	6/05	1 <sup>st</sup>	June/07 6/30/07	Yes
John Goetke ( /M) 2120 Bainbridge Road Stedman, NC 28391 484-4074/891-2238(W)	6/05	1 <sup>st</sup>	June/08 6/30/08	Yes
John D. Pone, Sr. (B/M) 2802 Blossom Road Hope Mills, NC 28348 323-0007/483-4043 & 484-3717(W)	8/05	1 <sup>st</sup>	June/08 6/30/08	Yes
Dean H. Smelcer, Jr. (W/M) 3209 Boone Trail Fayetteville, NC 28306 424-3423/425-1769(W)	8/05	1 <sup>st</sup>	June/08 6/30/08	Yes

Commissioner Liaison: John T. Henley, Jr.

Meetings: 1st Monday of every month at 5:45 PM – 121 Lamon Street

Contact: Robert Barefoot, City of Fayetteville (or Sharon Fulcher) 433-1547, fax # 433-1762

APPLICANTS FOR  
PARKS & RECREATION ADVISORY BOARD

<u>NAME/ADDRESS/TELEPHONE</u>	<u>OCCUPATION</u>	<u>EDUCATIONAL BACKGROUND</u>
ALLEN, CHARLES (W/M) 2233 WILMINGTON HIGHWAY FAYETTEVILLE, NC 28306 483-3213/323-8811(W)	OWNER – LANDSCAPING COMPANY	NURSERY & HORTICULTURE STUDIES
ALLEN, CINDY (W/F) 2233 WILMINGTON HIGHWAY FAYETTEVILLE, NC 28306 483-3213/323-8811(W)	OWNER – NURSERY & LANDSCAPING COMPANY	ASSOCIATE DEGREE: DENTAL ASSISTANT
<b>**SERVES ON THE JOINT APPEARANCE COMMISSION**</b>		
FADDIS, JAMES M. (W/M) 1871 WINDLOCK DRIVE FAYETTEVILLE, NC 28304 425-5739/396-6511 (W)	INFO TECH SUPERV. RETIRED ARMY	AS – ELECTRONICS TECH AA – GENERAL EDUCATION
HARTFIELD, ELISABETH A. (W/F) 1237 THISTLE GOLD DRIVE HOPE MILLS, NC 28348 429-0055/797-0755 (C)	NONE	DEGREE IN MECHANICAL ENGINEERING
MERCER, CARLON G. (W/M) 1846 WAYNE LANE FAYETTEVILLE, NC 28304 425-0243/624-4334 (C)	RETIRED	HS, CONTINUING EDUC COURSES
NIXON, GREGORY (B/M) 713 HOPE MILLS RD # 242 FAYETTEVILLE, NC 28304 826-4745/527-4745 (W)	OWNER – CLEANING BUSINESS	3 YRS OF COLLEGE
SULLIVAN, JOSEPH (Joe) (W/M) 2906 HIGH PLAINS DRIVE HOPE MILLS, NC 28348 717-1619/723-9227 (C)	SUBSTITUTE – RETIRED TEACHER	2 YR MASTERS
SUTTON, CARRIE (F) 5422 SUMMER DUCK ROAD FAYETTEVILLE, NC 28314 864-5567/483-7695 (W)	REP – BUSINESS	COLLEGE DEGREE (UNKNOWN)
WIGGS, CECIL (W/M) 6213 STONEY POINT LOOP FAYETTEVILLE, NC 28306 425-8557	RETIRED SCHOOL TEACHER	MASTERS -EDUCATION
YEPEZ, JOSE ( /M) 3900 FOSTER DRIVE FAYETTEVILLE, NC 28311 488-4423/728-8660	RETIRED	BS-BUSINESS AS-PUBLIC ADMIN



ITEM NO. 3L

## COUNTY of CUMBERLAND

*Office of the County Attorney*

May 16, 2007

**MEMORANDUM FOR BOARD OF COMMISSIONERS' MAY 21, 2007 AGENDA**

**TO: BOARD OF COMMISSIONERS**

**FROM: GRAINGER BARRETT, COUNTY ATTORNEY**

**SUBJECT: CONSIDERATION OF JOINT PLANNING BOARD REQUEST FOR EXTENSION OF TERM OF CLIFTON MCNEILL, JR.**

**BACKGROUND:** The Joint Planning Board voted unanimously at its meeting of May 15, 2007 respectfully to request that the Board of Commissioners consider extending the term of Clifton McNeill, Jr. for an additional year. Mr. McNeill will complete his second term on the Joint Planning Board this coming June 30, 2007. The Joint Planning Board notes that Mr. McNeill is a co-chair of the 2030 Plan Task Force and a representative of the Joint Planning Board on that body. The Joint Planning Board believes that his continued service in bringing the 2030 Plan to approval and in its initial implementation would be highly desirable and beneficial to the County. The Joint Planning Board also notes that Mr. McNeill is a member of its Land Use Codes Subcommittee, which is engaged in a thorough-going review and revision of the Subdivision Ordinance this year, and that his expertise, experience on the Board, and judgment will be invaluable in that process also.

Mr. McNeill has served as Chairperson and Vice-Chairperson of the Joint Planning Board and also has Chairperson of its Land Use Codes Subcommittee. Mr. McNeill served as a member of the Land Use Codes Subcommittee, and as Chairperson of the Joint Planning Board, when it comprehensively reviewed and recommended revisions to the Zoning Ordinance to the Board of Commissioners.

**RECOMMENDATION:** Consider whether to extend term of Clifton McNeill, Jr. on Joint Planning Board through June 30, 2008.

KENNETH S. EDGE  
Chairman

J. BREEDEN BLACKWELL  
Vice Chairman

JEANNETTE M. COUNCIL  
JOHN T. HENLEY, JR.  
BILLY R. KING  
EDWARD G. MELVIN  
DIANE WHEATLEY



ITEM NO. 3M  
MARSHA S. FOGLE  
Clerk to the Board  
MARIE COLGAN  
Deputy Clerk

**BOARD OF COMMISSIONERS**

5th Floor, New Courthouse • P.O. Box 1829 • Fayetteville, North Carolina 28302-1829  
(910) 678-7771 • Fax: (910) 678-7770

May 8, 2007

**May 21, 2007 Agenda Item**

TO: Board of Commissioners  
FROM: Marie Colgan, Deputy Clerk  
SUBJECT: Storm Water Advisory Board Vacancies (2)

The Storm Water Advisory Board will have the following vacancies on June 30, 2007:

**Nancy Smith** – Completing first term. Eligible for reappointment.

**Jennings McArthur** – Completing first term. Eligible for reappointment.

I have attached the current County membership list and applicant list for this board.

**PROPOSED ACTION:** Make nominations to fill the vacancies (2).

Attachments

cc: Greg Caison, Storm Water Services Manager

*Celebrating Our Past...Embracing Our Future*



STORM WATER ADVISORY BOARD  
2 Year Term  
(Staggered Terms Initially)

<u>Name/Address</u>	<u>Date Appointed</u>	<u>Term</u>	<u>Expires</u>	<u>Eligible For Reappointment</u>
<u>COUNTY APPOINTEES</u>				
Nancy Smith ( /F) 573 Christmasberry Court Fayetteville, NC 28312 487-1578/850-9398(Cell)	4/06 (to fill unexpired term)	1st	June/07 6/30/07	Yes
Jennings McArthur (W/M) 3827 Butler Nursery Road Fayetteville, NC 28306 323-5576/527-4824(Cell)	6/05	1st	June/07 6/30/07	Yes
Dennis Gould (W/M) 7099 Calamar Drive Fayetteville, NC 28314 860-2563/818-6384(Cell)	6/06	1st	June/08 6/30/08	Yes
<u>CITY APPOINTEES</u>				
Wendy Michener (W/F) 223 Hillside Avenue Fayetteville, NC 28301 323-3912/485-4108(W)	8/06	1st	June/08 6/30/08	Yes
Robert M. Bennett (W/M) 1828 Conover Drive Fayetteville, NC 28303 425-2689/484-5523(W)	6/05	2nd	June/07 6/30/07	No
Joseph E. Glass (W/M) 136 Highgrove Court Fayetteville, NC 28303 860-1231/223-4740(W)	6/05	2nd	June/07 6/30/07	No

<u>Name/Address</u>	<u>Date Appointed</u>	<u>Term</u>	<u>Expires</u>	<u>Eligible For Reappointment</u>
---------------------	---------------------------	-------------	----------------	---------------------------------------

JOINT APPOINTEE  
(Appointed by the Chairman and the Mayor)

Dohn Broadwell, Jr. 1600 Rock Hill Road Fayetteville, NC 28301 485-6065(H)	6/06	2nd	June/08 6/30/08	No
-------------------------------------------------------------------------------------	------	-----	--------------------	----

Ex-Officio Members: Fort Bragg, Pope Air Force Base and N.C.D.O.T.

Contact: Sally Dahlstrom (City) 433-1648 - fax # 433-1058

Meetings: 1<sup>st</sup> Tues – 5:30 pm, City Hall, 1<sup>st</sup> Floor, LaFayette Room

Board was established July, 1995.

APPLICANTS FOR  
STORM WATER ADVISORY BOARD

<u>NAME/ADDRESS/TELEPHONE</u>	<u>OCCUPATION</u>	<u>EDUCATIONAL BACKGROUND</u>
MERCER, CARLON G. (W/M) 1846 WAYNE LANE FAYETTEVILLE, NC 28304 425-0243/624-4334 (C)	RETIRED	HS, CONTINUING EDUC COURSES

KENNETH S. EDGE  
Chairman

J. BREEDEN BLACKWELL  
Vice Chairman

JEANNETTE M. COUNCIL  
JOHN T. HENLEY, JR.  
BILLY R. KING  
EDWARD G. MELVIN  
DIANE WHEATLEY



MARSHA S. FOGLE  
Clerk to the Board

MARIE COLGAN  
Deputy Clerk

**BOARD OF COMMISSIONERS**

5th Floor, New Courthouse • P.O. Box 1829 • Fayetteville, North Carolina 28302-1829  
(910) 678-7771 • Fax: (910) 678-7770

May 7, 2007

**May 21, 2007 Agenda Item**

TO: Board of Commissioners

FROM: Marie Colgan, Deputy Clerk

SUBJECT: Adult Care Home Community Advisory Committee

BACKGROUND: On May 7, 2007, the Board of Commissioners nominated the following for her initial term on the Adult Care Home Community Advisory Committee:

Nominee: **Benita Briggs**

I have attached the current membership list for this committee.

**PROPOSED ACTION: Appoint the above vacancy.**

Attachment

cc: Andrea Wright-Valdez, Mid-Carolina Area Agency on Aging

ADULT CARE HOME COMMUNITY ADVISORY COMMITTEE  
Initial Appointment 1 Year/Subsequent Term 3 Years

<u>Name/Address</u>	<u>Date Appointed</u>	<u>Term</u>	<u>Expires</u>	<u>Eligible For Reappointment</u>
Ernestine Mack ( /F) 6916 Kizer Drive Fayetteville, NC 28314 717-4229	2/07	Initial	Feb/08 2/28/08	Yes
Lonnie E. Johnson (B/M) 5206 Landmark Drive Fayetteville, NC 28311 488-8372/224-4841(C)	02/07	Initial	Feb/08 02/28/08	Yes
Mary Ann Brown-Jackson 1959B James Hamner Way Fayetteville, NC 28311 822-1311/483-3101	1/06	1 <sup>st</sup>	Jan/09 1/31/09	Yes
Edgar F. Merritt (B/M) 1506 Boros Drive Fayetteville, NC 28303 822-2976/286-2552(W)	10/06	Initial	Oct/07 10/31/07	Yes
Herma Jean Bradley ( /F) 714 Topeka Street Fayetteville, NC 28301 822-3689	6/06	1 <sup>st</sup>	June/09 6/30/09	Yes
Mexie Fields ( /F) 1815 Primrose Drive Fayetteville, NC 28301 488-8432	1/06	1 <sup>st</sup>	Jan/10 1/31/10	Yes
James Ingram (B/M) P.O. Box 87671 Fayetteville, NC 28304 257-1831/488-8415(W)	1/05	1 <sup>st</sup>	Jan/10 1/31/10	Yes
Julie Smith 3705 Tyson Circle Hope Mills, NC 28348 425-6215	9/05	1 <sup>st</sup>	Aug/08 8/31/08	Yes

Adult Care Home Community Advisory Committee, page 2

<u>Name/Address</u>	<u>Date Appointed</u>	<u>Term</u>	<u>Expires</u>	<u>Eligible For Reappointment</u>
Jacqueline S. Wolfe (W/F) 1812 Manchester Street Fayetteville, NC 28303 484-8588/484-5146 (W)	2/07	Initial	Feb/08 2/28/08	Yes
Stephanie Hodges (W/F) 3424 Harrisburg Road Fayetteville, NC 28306 429-9300/292-5651(Cell)	10/06	1 <sup>st</sup>	Nov/09 11/30/09	Yes
Wynella A. Myers (B/F) 706 Sarazan Drive Fayetteville, NC 28303 425-3732	9/06	Initial	Aug/07 8/31/07	Yes
Janet Pelley 6131 Lochview Drive Fayetteville, NC 28311 488-4947	4/06	2 <sup>nd</sup>	April/09 4/30/09	No
John Poulos (W/M) 3025 Brechin Road Fayetteville, NC 28303 867-2622/424-4242(W)	6/06	2 <sup>nd</sup>	June/09 6/30/09	No
Teresa R. McNeill (B/F) 3518 Pickerel Street Fayetteville, NC 283068 480-0313/483-3648, Ext. 1109 (W)	2/07	Initial	Feb/08 2/28/08	Yes
Dr. Claudett Tompkins (B/F) 260 Old Farm Road Fayetteville, NC 28314 864-5336/424-4797(W)	9/06	2 <sup>nd</sup>	Aug/09 8/31/09	No
Kim Howard ( _/F) 6018 Lakaway Drive Fayetteville, NC 28306 308-5974	4/07	Initial	Apr/08 4/30/08	Yes

CONTACT: Andrea Wright-Valdez, Regional Ombudsman, Mid-Carolina Area Agency on Aging,  
P. O. Box 1510, Fayetteville, NC 28302. Phone: 323-4191, x 25, fax # 323-9330  
MEETINGS: Quarterly: March, June, September, December 1st Thursday of Particular Month,  
10:00 AM, Blue Street Senior Center

KENNETH S. EDGE  
Chairman

J. BREEDEN BLACKWELL  
Vice Chairman

JEANNETTE M. COUNCIL  
JOHN T. HENLEY, JR.  
BILLY R. KING  
EDWARD G. MELVIN  
DIANE WHEATLEY

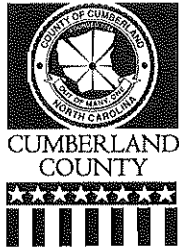

MARSHA S. FOGLE  
Clerk to the Board

MARIE COLGAN  
Deputy Clerk

**BOARD OF COMMISSIONERS**

5th Floor, New Courthouse • P.O. Box 1829 • Fayetteville, North Carolina 28302-1829  
(910) 678-7771 • Fax: (910) 678-7770

May 7, 2007

**May 21, 2007 Agenda Item**

TO: Board of Commissioners  
FROM: Marie Colgan, Deputy Clerk *MC*  
SUBJECT: Appointments to the Community Child Protection Fatality Prevention Team

BACKGROUND: On May 7, 2007, the Board of Commissioners nominated the following to fill three (3) vacancies on the Community Child Protection Fatality Prevention Team:

Nominees:	<u>EMS Provider or Firefighter Position</u>	<b>Barry Childers</b> (new appointment to fill unexpired term)
	<u>Parent of a Child Who Died Before Reaching Their 18<sup>th</sup> Birthday Position</u>	<b>Tonya Vetter</b> (new appointment)
	<u>At Large Position</u>	<b>Maxine Anders</b> (new appointment to fill unexpired term)

I have attached the current membership list for this board.

**PROPOSED ACTION: Appoint the above three vacancies.**

Attachment

cc: Gail Rios, Review Coordinator, CCPFPT

*Celebrating Our Past...Embracing Our Future*

CUMBERLAND COUNTY 4/07  
COMMUNITY CHILD PROTECTION/FATALITY PREVENTION TEAM  
(County Commissioner Appointees)  
3 Year Terms

<u>Name/Address</u>	<u>Date</u> <u>Appointed</u>	<u>Term</u>	<u>Expires</u>	<u>Eligible For</u> <u>Reappointment</u>
<u>Law Enforcement Officer Position</u>				
<u>Sheriff's Office:</u>				
Melody Farnham CC Sheriff's Office 131 Dick Street Fayetteville, NC 28301 677-5475	4/07	1st	Apr/10 4/30/10	Yes
<u>Fayetteville City Police Department:</u>				
Bill Mitrising Fayetteville Police Dept. 467 Hay Street Fayetteville, NC 28301 433-1855	4/07	1st	Apr/10 4/30/10	Yes
<u>EMS Provider or Firefighter Position</u>				
Carl Strange 1557 Magnolia Church Road (to fill unexp. term) Stedman, NC 28391 584-8674/678-2076(Cell)	9/05	1st	Sept/08 9/30/08	Yes
<u>Parent of a Child Who Died Before Reaching Their 18th Birthday Position</u>				
Vacant as of 11-30-06 (agency to provide name of replacement for Vivian Strickland when possible)				
<u>At-Large Positions</u>				
Allie D. Wiggins 5222 Brookfield Road Fayetteville, NC 28303 868-4219/988-4267(Cell)	11/06	1st full	Nov/09 11/30/09	Yes
Kalisha Abercrombie 3804 Casper Street Fayetteville, NC 28348 797-2537/864-7230(W)	11/06	1st	Nov/09 11/30/09	Yes
Dr. David Smith 210 West Summerchase Drive Fayetteville, NC 28311 822-1766/609-4341(W)	9/05	2nd	Sept/08 09/30/08	No

Contact: Gail Rios (DSS) – 677-2045 (Fax: 677-2091)  
Meets the 3<sup>rd</sup> Thursday of each month at 3:15 pm – DSS, 4<sup>th</sup> Floor, Room 440



KENNETH S. EDGE  
Chairman

J. BREEDEN BLACKWELL  
Vice Chairman

JEANNETTE M. COUNCIL  
JOHN T. HENLEY, JR.  
BILLY R. KING  
EDWARD G. MELVIN  
DIANE WHEATLEY

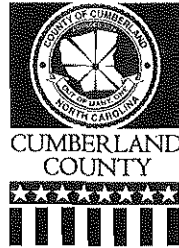

MARSHA S. FOGLE  
Clerk to the Board

MARIE COLGAN  
Deputy Clerk

**BOARD OF COMMISSIONERS**

5th Floor, New Courthouse • P.O. Box 1829 • Fayetteville, North Carolina 28302-1829  
(910) 678-7771 • Fax: (910) 678-7770

May 7, 2007

**May 21, 2007 Agenda Item**

**MEMORANDUM**

TO: Board of Commissioners  
FROM: Marie Colgan, Deputy Clerk  
SUBJECT: Juvenile Crime Prevention Council

BACKGROUND: On May 7, 2007, the Board of Commissioners nominated the following to fill the following vacancy on the Juvenile Crime Prevention Council:

Nominees: Member of Faith Community: **Rev. Brian Thompson**  
(reappointment)

I have attached the current membership list for this council.

**PROPOSED ACTION: Appoint the above.**

Attachments

cc: Sarah Hemingway, CCJPC Coordinator

CUMBERLAND COUNTY  
 JUVENILE CRIME PREVENTION COUNCIL  
 (Two year terms)

<u>Name/Address</u>	<u>Date Appointed</u>	<u>Term</u>	<u>Expires</u>	<u>Eligible For Reappointment</u>
<u>Local School Superintendent or designee</u>				
Carol Hudson Cumberland County Schools P.O. Box 2357 Fayetteville, North Carolina 28302 Phone: 678-2495	1/99			
<u>Chief of Police or designee</u>				
Lt. Sherry Sparks Fayetteville Police Department 467 Hay Street Phone: 433-1910	11/05			
<u>Local Sheriff or designee</u>				
Lt. Lynette Hodges Cumberland County Sheriff's Office 131 Dick Street Fayetteville, North Carolina 28301 Phone: 677-5474	1/07			
<u>District Attorney or designee</u>				
Cheri Siler-Mack Assistant District Attorney District Attorney's Office 117 Dick Street, Suite 427 Fayetteville, North Carolina 28301 Phone: 678-2915	1/99			
<u>Chief Court Counselor or designee</u>				
Joan Blanchard Department of Juvenile Justice P.O. Box 363 Fayetteville, North Carolina 28302 Phone: 678-2947	11/03			
<u>Director of Mental Health or designee</u>				
Debbie Jenkins Cumberland County Mental Health Center P.O. Box 3069 Fayetteville, North Carolina 28302 Phone: 323-0510	10/03			

Cumberland County Juvenile Crime Prevention Council Page 2

<u>Name/Address</u>	<u>Date Appointed</u>	<u>Term</u>	<u>Expires</u>	<u>Eligible For Reappointment</u>
<u>Director of Social Services or designee</u>				
Ms. Lee Roberts Child Protection and Placement Treatment Program Manager Cumberland County Department of Social Services P.O. Box 2429 Fayetteville, North Carolina 28302-2429 Phone: 677-2422	1/99			
<u>County Manager or designee</u>				
Juanita Pilgrim, Deputy Co. Mgr. Cumberland County Courthouse P.O. Box 1829 Fayetteville, North Carolina 28302-1829 Phone: 678-7726	1/99			
<u>Chief District Judge or designee</u>				
Judge Ed Pone P.O. Box 363 Fayetteville, North Carolina 28302 Phone: 678-2901	1/99			
<u>Health Director or designee</u>				
Archie Malloy Jail Health Administrator 205 Gillespie Street Fayetteville, North Carolina 28301 Phone: 672-5723	3/06			
<u>Parks and Recreation Representative</u>				
Melvin Lindsay City of Fayetteville Parks and Recreation Dept. 433 Hay Street Fayetteville, North Carolina 28301 Phone: 433-1547	2/05			
<u>County Commissioner</u>				
Billy R. King P.O. Box 1829 Fayetteville, NC 28302-1829 Phone: 678-7771	1/99			

Cumberland County Juvenile Crime Prevention Council, Page 3

<u>Name/Address</u>	<u>Date Appointed</u>	<u>Term</u>	<u>Expires</u>	<u>Eligible For Reappointment</u>
<u>Substance Abuse Professional</u>				
Lynett Shakeel CC Mental Health 109 Bradford Avenue Fayetteville, NC 28301 222-6093(W)	8/05	1st	Aug/07 8/31/07	Yes
<u>Member of Faith Community</u>				
Rev. Brian Thompson 3942 Gaithersburg Lane Hope Mills, NC 28348 436-2462/867-2708(W)	5/05	1st	May/07 5/31/07	Yes
<u>Person Under Age 21</u>				
Shakeema Burns 1317 Alexwood Drive Hope Mills, NC 28348 423-0180	8/04	2nd	Aug/06 8/31/06	No
<u>Juvenile Defense Attorney</u>				
Beth A. Hall 4508 Weaverhall Drive Fayetteville, NC 28314 257-0847(Cell)	9/06	1st full	Aug/08 8/31/08	Yes
<u>Member of Business Community</u>				
Gene Hallock 173 Aloha Drive Fayetteville, NC 28311 822-5409	8/05	1st	Aug/07 8/31/07	Yes
<u>United Way or Non-Profit</u>				
Margarita Dostall CC Schools P.O. Box 2357 Fayetteville, NC 28302 678-2300	2/06	2nd	Jan/08 1/31/08	No
<u>At Large Representatives</u>				
Henry Berry 1722 Eldridge Street Fayetteville, North Carolina 28301 Phone: 396-5521	8/04	2nd	Aug/06 8/31/06	No

Cumberland County Juvenile Crime Prevention Council, Page 4

<u>Name/Address</u>	<u>Date Appointed</u>	<u>Term</u>	<u>Expires</u>	<u>Eligible For Reappointment</u>
John Clark Juvenile Assessment Center 121 Lamon Street Fayetteville, North Carolina 28301 Phone: 323-5070/433-1116	9/06	1st full	Aug/08 8/31/08	Yes
Dr. Polly Davis FTCC P.O. Box 35236 Fayetteville, North Carolina 28303 Phone: 678-8322	6/05	1st	Aug/07 8/31/07	Yes
Ron Snyder 7008 Hounds Ear Court Fayetteville, North Carolina 28311 Phone: 488-1388	6/05	2nd	Aug/07 8/31/07	No
Sue Thomas 3741 Harrisburg Drive Fayetteville, North Carolina 28306 Phone: 425-8868	6/05	1st	Aug/07 8/31/07	Yes
Patrick Hurley, Director Workforce Development Center P.O. Box 1829 Fayetteville, North Carolina 28302 Phone: 484-3044/323-3421(W)	8/05	2nd	Aug/07 8/31/07	No
Krista Hancock 4H Agent – Cooperative Extension 301 E. Mountain Drive Fayetteville, North Carolina 28306 Phone: 321-6867	4/06	2nd	Apr/08 4/30/08	No

Non-Voting Member

Cindy Holmes  
DJJDP Regional Consultant  
108 N. Orange Street  
Dunn, North Carolina 28334  
Phone: 919-733-3388(W)

Meetings: Second Wednesday of each month at 8:00 AM. CC CommuniCare Conference Room – 711B Executive Place

Contact: Sarah Hemingway – Phone: 829-9017 - Fax: 485-4752

---

---

**KELLY HILLS/SLOCOMB ROAD WATER & SEWER DISTRICT  
GOVERNING BOARD AGENDA  
SPECIAL MEETING  
CUMBERLAND COUNTY BOARD OF COMMISSIONERS  
COURTHOUSE – ROOM 118  
MAY 21, 2007  
6:45 PM**

---

---

INVOCATION

1. Items of Business
  - A. Approval of minutes for the March 19, 2007 special meeting.
  - B. Approval of Budget Revision B07-341 and B07-341A for Maintenance Fund.

**ADJOURN THE MAY 21, 2007 SPECIAL MEETING OF THE KELLY HILLS/  
SLOCOMB ROAD WATER & SEWER DISTRICT GOVERNING BOARD.**

**THIS MEETING WILL BE BROADCAST LIVE ON TIME WARNER  
COMMUNITY CHANNEL 7.**

**COUNTY OF CUMBERLAND  
BUDGET REVISION REQUEST**

Budget Office Use	Kelly Hills -02
Budget Revision No.	B07-341
Date Received	5/9/2007
Date Completed	

Fund No. 255 Agency No. 450 Organ. No. 450F  
 Organization Name: Kelly Hills Water & Sewer

ITEM NO. 13

**REVENUE**

*pg 1 of 2*

Revenue Source Code	Description	Current Budget	Increase (Decrease)	Revised Budget
6689	Maintenance & Repair Water/Sewer Fees	0	400	400
9130	Transfer from Fund 010	0	24,504	24,504
Total		0	24,904	24,904

**EXPENDITURES**

Object Code	Appr Unit	Description	Current Budget	Increase (Decrease)	Revised Budget
3435	759	Maintenance & Repair Other	0	24,904	24,904
Total			0	24,904	24,904

**Justification:**

Transfer sales tax revenue and maintenance fees from the Kelly Hills capital project fund to the Kelly Hills maintenance fund.

Funding Source: State: \_\_\_\_\_ Federal: \_\_\_\_\_ Fees: \_\_\_\_\_ Other: \_\_\_\_\_  
 Fund Balance: County: \_\_\_\_\_ New: \_\_\_\_\_ Prior Year: \_\_\_\_\_ Other: \_\_\_\_\_

Submitted By: \_\_\_\_\_ Date: \_\_\_\_\_  
 Reviewed By: HCA [Signature] Department Head Date: 5/9/07  
 Reviewed By: [Signature] Budget Analyst Date: 5/16/07  
 Reviewed By: \_\_\_\_\_ Deputy Assistant County Mgr Date: \_\_\_\_\_  
 Reviewed By: \_\_\_\_\_ Information Services Date: \_\_\_\_\_

Approved By:	
County Manager	Date: _____
Board of County Commissioners	Date: _____

**COUNTY OF CUMBERLAND  
BUDGET REVISION REQUEST**

Budget Office Use	Kelly Hills -02A
Budget Revision No.	B07-341A
Date Received	5/9/2007
Date Completed	

Fund No. 010 Agency No. 450 Organ. No. 450B  
 Organization Name: Kelly Hills Water & Sewer

Pg. 2 of 2

**REVENUE**

Revenue Source Code	Description	Current Budget	Increase (Decrease)	Revised Budget
---------------------	-------------	----------------	---------------------	----------------

Total  
**EXPENDITURES**

Object Code	Appr Unit	Description	Current Budget	Increase (Decrease)	Revised Budget
3791	NBE	Construction	2,994,256	(24,504)	2,969,752
389U	NBF	Transfer to Fund 255	0	24,504	24,504

Total      2,994,256      -      2,994,256

**Justification:**

Transfer sales tax revenue and maintenance fees from the Kelly Hills capital project fund to the Kelly Hills maintenance fund.

**Funding Source:**

State: \_\_\_\_\_ Federal: \_\_\_\_\_ County: \_\_\_\_\_ New: \_\_\_\_\_ Other: \_\_\_\_\_  
 Other: \_\_\_\_\_ Fees: \_\_\_\_\_ Prior Year: \_\_\_\_\_

**Fund Balance:**

Submitted By: \_\_\_\_\_ Date: \_\_\_\_\_  
 Department Head  
 Reviewed By: HEA \_\_\_\_\_ Date: 5/9/07  
 Budget Analyst  
 Reviewed By: Amyl Cannon \_\_\_\_\_ Date: 5/16/07  
 Deputy Assistant County Mgr  
 Reviewed By: \_\_\_\_\_ Date: \_\_\_\_\_  
 Information Services

<b>Approved By:</b>	
_____	Date: _____
County Manager	
Board of County Commissioners	
_____	Date: _____



ITEM NO. 5A

# CLOSED SESSION

**Personnel Matter(s) Pursuant  
to NCGS 143-318.11(a)(6)**